

## Installation and operation manual

### CLEARPOINT® 3eco coalescing filter

> S040  
> S050  
> S055

> S075  
> M010  
> M012

> M015  
> M018  
> M020  
> M022  
> M023

> M025  
> M027  
> M030  
> M032

## ■ Content

<b>1. General</b>	<b>4</b>
1.1 Contact	4
1.2 Information regarding installation and operation manual	4
1.3 Other applicable documents	4
1.4 Explanation of the symbols and pictograms utilised	5
1.4.1 In the documentation	5
1.4.2 On the device	6
1.5 Intended use	7
1.6 Reasonably foreseeable inappropriate use	8
1.7 Legal warranty and liability for property defects	8
1.8 Target group and personnel	9
1.9 Responsibility of the owner	9
<b>2. Safety-related information</b>	<b>10</b>
2.1 General instructions	10
2.2 Safety instructions	11
<b>3. Transport and storage</b>	<b>12</b>
<b>4. Product information</b>	<b>13</b>
4.1 Product description	13
4.2 Product overview	13
4.3 Product identification	14
4.4 Function description	16
4.4.1 Filtration	16
4.4.2 Condensate discharge through float drain	17
4.4.3 Condensate discharge through BEKOMAT	18
4.5 Scope of delivery	18
4.6 Type plate	19
4.7 Filter element sticker	20
4.8 Maintenance sticker for filter element replacement	20
<b>5. Technical data</b>	<b>21</b>
5.1 Filter performance data	21
5.2 Filter element performance data	22
5.3 Materials	23
<b>6. Dimensions</b>	<b>24</b>
<b>7. Assembly</b>	<b>26</b>
7.1 Warning	26
7.2 Assembly work	27
<b>8. Commissioning</b>	<b>29</b>
8.1 Commissioning tasks	29
<b>9. Maintenance and servicing</b>	<b>30</b>
9.1 Maintenance schedule	30
9.2 Cleaning	30
9.2.1 Warning	30
9.2.2 Cleaning work	31
9.3 Visual inspection	31
9.4 Replace the float drain	32
9.5 Replace the filter element	36

---

9.6 Leakage test .....	39
<b>10. Shut down .....</b>	<b>40</b>
<b>11. Disassembly .....</b>	<b>41</b>
11.1 Warning.....	41
11.2 Disassembly work.....	42
<b>12. Disposal .....</b>	<b>44</b>
12.1 Warning.....	44
12.2 Disposal work .....	44
<b>13. Spare parts and accessories.....</b>	<b>45</b>
13.1 Spare parts .....	45
13.2 Accessories attachment components top .....	45
13.3 Accessories attachment components bottom.....	46
<b>14. Troubleshooting / FAQ.....</b>	<b>47</b>
<b>15. Product approvals and registration marks .....</b>	<b>48</b>

# 1. General

## 1.1 Contact

Manufacturer	Customer service and tools
<p><b>BEKO TECHNOLOGIES GmbH</b></p> <p>Im Taubental 7   D-41468 Neuss                      Tel. + 49 2131 988 - 1000                      info@beko-technologies.com                      www.beko-technologies.com</p>	<p><b>BEKO TECHNOLOGIES GmbH</b></p> <p>Im Taubental 7   D-41468 Neuss                      Tel. + 49 2131 988 - 1000                      service-eu@beko-technologies.com                      www.beko-technologies.com</p>

## 1.2 Information regarding installation and operation manual

INFORMATION	Copyright protection
	<p>The contents of the installation and operation manual in the form of text, figures, illustrations, photographs, technical drawings, diagrams and other representations are protected by the copyright of the manufacturer. This applies especially to duplication, reproduction, microfilming and storage as well as processing in electronic systems.</p>

Publication date	Revision status	Reason for amendment	Scope of amendment
31/10/2018	00_01	Changes to standards and regulations	Completely new version

The installation and operation manual, hereinafter referred to as the manual, must always be stored close to the product and be in a permanently legible condition.

The manual must be handed over along with the product if it is sold or passed on.

NOTE	Follow the instructions given in the manual!
	<p>This manual contains all the basic information required for safe operation of the product and must therefore be read before any actions are performed. Otherwise personal and material hazards as well as functional and operational malfunctions can occur.</p>

## 1.3 Other applicable documents











This manual contains all the necessary steps for installation and operation of the CLEARPOINT® 3eco coalescing filter. More detailed information about the installation and operation of the accessories is contained in the following installation and operation manual:

- BEKOMAT® 20
- BEKOMAT® 20 FM
- CLEARPOINT® Differential pressure gauge





## 1.4 Explanation of the symbols and pictograms utilised

The symbols and pictograms utilised below indicate safety-relevant and important information which must be adhered to when handling the operating material and to ensure safe and optimum operation.

### 1.4.1 In the documentation

Symbol/Pictogram	Description/Explanation
	General hazard symbol (danger, warning, caution)
	Pressurised system
	Observe installation and operating manual
	General instructions
	Wear respiratory protection FFP 3
	Wear safety footwear
	Wear protective gloves (fluid-resistant)
	Wear hearing protection
	Wear safety goggles with side shields
	General information

## 1.4.2 On the device

Symbol/Pictogram	Description/Explanation
	<p><b>General hazard symbol (danger, warning, caution)</b>            (This symbol can be found on the type plate and on the maintenance sticker for filter element replacement.)</p>
	<p><b>Maintenance sticker for filter element replacement</b>            When the next scheduled filter element replacement is due is marked on this sticker, and that the installation and operation manual should be followed.</p>
	<p><b>Filter element sticker</b>            This sticker is located on the base of the filter element and provides information about the filter element and the direction of flow.</p>
	<p><b>eco label:</b>            Products with this sticker have special added value in the form of energy saving and are allocated to the <b>eco</b> line of <b>BEKO TECHNOLOGIES GMBH</b> products.</p>

## 1.5 Intended use

### **CLEARPOINT® filters and accessories**

The CLEARPOINT® 3eco coalescing filter, also referred to as filter below, is used for the filtration of aerosols and solid particles in compressed gas systems.

Any use of this system other than the use described in this manual is hereby deemed to be non-intended and can cause a hazard for the safety of people and the environment.

- Only use filters and accessories within the operating parameters given in the technical data and the agreed delivery conditions.
- Only use filters and accessories within a pipeline system designed for the technical data with appropriate connections, pipe diameters and assembly clearance.
- Only use the filters and accessories for the treatment of compressed gases of fluid group 2 according to Pressure Equipment Directive 2014/68/EU which are free of aggressive and corrosive components.
- Only use filters and accessories in non-explosive hazardous areas.
- Only use filters and accessories away from direct solar radiation and heat sources as well as areas subject to frost.
- Only combine the filters and accessories with the products named and recommended by **BEKO TECHNOLOGIES GMBH** in the manual.

Before using the filters, the operating company must make sure that all conditions and prerequisites for intended use are given.

The filter is exclusively designed for stationary use in a commercial or industrial area. All the assembly, installation, operation, disassembly and disposal work described may only be performed by qualified skilled personnel.

## 1.6 Reasonably foreseeable inappropriate use

Reasonably foreseeable inappropriate use is deemed to have occurred if the filter or any accessories are used in any other way than that described in the chapter "Intended use". Reasonably foreseeable inappropriate use includes the use of the product in a manner not intended by the manufacturer or supplier but which may result from foreseeable human behaviour.

Reasonably foreseeable inappropriate use includes:

- Executing of modifications of all kinds, in particular design and process engineering interventions, as these can lead to personal injury and material damage as well as functional and operational malfunctions and device failure.
- The overriding, bridging or non-application of existing or recommended safety devices.
- The use for treatment of compressed gases which are not included in fluid group 2 in accordance with PED 2014/68/EU or contain aggressive components. In cases of doubt a gas/condensate analysis must be carried out.

This list is not exhaustive as not all possible inappropriate use can be foreseen in advance. If the operating company is aware of any inappropriate use of the filter or accessories which are not listed here, the manufacturer must be informed immediately.

## 1.7 Legal warranty and liability for property defects

The owner and operator must take into account the intended use. The owner and operator will be completely liable for every not described action and utilisation which exceeds the stated intended use.

All liability or warranty claims will be invalidated insofar as the filter is not operated according to the intended use or is operated outside the limits specified in the technical data.

This includes:

- incorrect technical installation, commissioning, servicing, maintenance or operation
- the use of defective components
- non-compliance with the safety-relevant information, action steps and instruction contained in this manual
- the performance of any kind of modification, in particular constructive and process technology interventions on the product
- the use of third-party spare parts or accessories, which have not been approved by the manufacturer, during maintenance and repair work
- Non-compliance with servicing, maintenance and inspection intervals



## 1.8 Target group and personnel

This manual addresses the specialist personnel listed below who are involved with work on the filter or the accessories.

INFORMATION	Personnel requirements
	<p>The personnel may not execute any actions on the filter or the accessories when they are under the influence of drugs, medications, alcohol or other substances that may impair their consciousness.</p>

### Skilled personnel- Transport and storage

Skilled personnel - Transport and storage are people who, due to their training, professional experience and qualifications, have all the necessary skills to safely execute all actions in connection with the transport and storage of the operating material, to instruct, to recognise possible dangerous situations independently and to execute measures to avoid danger.  
 Skills include experience with hoists, forklifts and lifting equipment and knowledge of local laws, standards and guidelines relating to transport and storage.

### Qualified personnel - compressed gas technology

Skilled personnel - compressed gas technology are people who, due to their training, professional experience and qualification, possess all the necessary capabilities to safely execute actions, and instruct all actions related to compressed gases and pressurised systems, to independently foresee potential hazardous situations and implement appropriate measures to avert any danger.  
 The capabilities include, in particular, experience in handling measurement and control technology as well as knowledge of the regionally applicable laws, standards and regulations for compressed gas technology.

## 1.9 Responsibility of the owner

The responsible owner must ensure the following to prevent accidents, incidents and adverse effects on the environment:

- Before all actions, check to ensure that the manual available does in fact belong to the product.
- Always use, maintain and service the product properly.
- All applicable statutory requirements, safety regulations and accident prevention regulations have been adhered to.
- All regulations and operation manual for safe working and information regarding behaviour in the event of accidents and fires at the operating location are accessible to personnel at all times.
- The product is used with recommended and functioning safety devices that are not overridden.
- Always have assembly, installation and maintenance work carried out by qualified skilled personnel only.
- Personnel have the recommended personal protective equipment at their disposal and it is used.
- Appropriate technical safety measures have been implemented to ensure that the permissible operating parameters are not exceeded or undershot.

## 2. Safety-related information

### 2.1 General instructions

Safety instructions warn against residual risks when handling the product. Warning notices in the instructional text precede the procedure that poses a hazard to personnel or the environment.

These safety and warning notices must be strictly observed in order to prevent accidents, personal injury, damage to property and impairments during operation.

#### Structure of the safety instructions

The content of the safety instructions is based on the **SAFE principle**:

- S - Safety symbol and signal word
- A - Type and source of danger
- F - Possible consequences of disregarding the danger in the order of its severity
- E - Measures to prevent danger

#### Structural design of the safety instructions:

SIGNAL WORD	Type and source of danger!
 Safety symbol	Possible consequences if the danger is ignored
	<ul style="list-style-type: none"> <li>• Measure to prevent the danger</li> </ul>





#### Signal words according to ISO 3864 and ANSI Z.535.6

<b>DANGER</b>	<b>Imminent danger</b> Consequences of non-compliance: Death or serious personal injury
<b>WARNING</b>	<b>Imminent danger</b> Consequences of non-compliance: Death or serious personal injury are possible
<b>CAUTION</b>	<b>Potential danger</b> Consequences of non-compliance: injury and/or damage to property
<b>NOTE</b>	<b>Additional notes, information, tips</b> Consequences of non-compliance: Disadvantages during operation, actions and maintenance. No danger to people or regarding the safe operation.



## 2.2 Safety instructions

In order to prevent accidents, personal injury and damage to the device as well as impairments during operation, it is essential to adhere to the specified safety and warning notices.

The personal protective equipment specified in the safety instructions must be selected and made available by the operating company depending on the system parameters and properties.

<b>DANGER</b>	<b>Operation of plant outside the permissible limit range!</b>
	<p>Operation of the product outside the permissible limits and operating parameters, unauthorised intervention and modifications may result in death or serious injury.</p>
	<ul style="list-style-type: none"> <li>• For safe operation of the product, always adhere to the limit values, operating parameters and maintenance intervals as well as the set-up and ambient conditions specified on the type plate and in the manual.</li> <li>• Inspect whether the operating parameters have been amended or restricted by the use of accessories.</li> <li>• Only use the product for its intended use.</li> </ul>
<b>DANGER</b>	<b>Pressurised system!</b>
	<p>Death or serious personal injury can result through contact with fast or suddenly escaping compressed air or through bursting system parts</p>
	<ul style="list-style-type: none"> <li>• All work on the system must be carried out in the depressurised state and with the system secured against unintentional pressure build-up.</li> <li>• Set up a safety zone around the system during all assembly, installation, maintenance and repair work.</li> <li>• Before applying pressure to the system, check all pipe connections and tighten if necessary.</li> <li>• Slowly pressurise the system with compressed gas.</li> <li>• Avoid pressure blows and high differential pressures.</li> <li>• Assemble all pipes without mechanical stress. Avoid any vibrations occurring in the pipe network by using vibration dampers.</li> <li>• Always keep exactly to the installation and operating instructions given in this manual.</li> <li>• Always keep inspection and maintenance interval exactly.</li> <li>• Install fixed pipes as supply and discharge pipes.</li> <li>• Do not carry out any structural changes to the product.</li> </ul>
<b>DANGER</b>	<b>Use of incorrect spare parts, accessories or installation materials!</b>
	<p>The use of incorrect spare parts, accessories or installation materials, as well as auxiliary and operating materials, may result in death or serious injury. In addition, functional and operational malfunctions or material damage can occur.</p>
	<ul style="list-style-type: none"> <li>• For all installation, servicing and maintenance work, only use undamaged original parts, auxiliary and operating materials which are specified by the manufacturer.</li> <li>• Only use fittings and connecting elements approved for the respective application as well as suitable tools in perfect operating condition.</li> <li>• Only use cleaned pipes that are free of dirt and corrosion.</li> </ul>
<b>WARNING</b>	<b>Non-application of personal protective equipment!</b>
	<p>Non-application of personal protective equipment or the use of sub-standard protective equipment can lead to accidents or personal injuries during work on the product.</p>
	<ul style="list-style-type: none"> <li>• The personal protective equipment recommended, which must be in a flawless condition, must be worn during all work on the product.</li> <li>• Inspect the personal protective equipment regularly for flawlessness and functionality and replace damaged parts immediately.</li> </ul>
<b>WARNING</b>	<b>Insufficient qualification!</b>
	<p>Insufficient qualification of the personnel can lead to accidents, personal injury and damage to the device as well as impairments during work on the operating material.</p>
	<p>All work on the product may only be carried out by appropriately qualified skilled personnel.</p>

### 3. Transport and storage

<b>WARNING</b>	<b>Insufficient qualification!</b>
	<p>Insufficient qualification of the personnel can lead to accidents, personal injury and damage to the device as well as impairments during work on the operating material.</p> <p>The work on the operating material described below must only be executed by specialist personnel during transport and storage.</p>
<b>CAUTION</b>	<b>Inappropriate transport or storage!</b>
	<p>Inappropriate transport or storage may result in personal injury or damage to the device.</p> <ul style="list-style-type: none"> <li>• Wear protective gloves when working with packaging material</li> <li>• Use personal protective equipment, inspect it regularly for faultlessness and functionality and replace damaged parts immediately.</li> <li>• The operating material may only be transported or stored by qualified personnel.</li> <li>• Handle packaging and operating material with care.</li> <li>• Pack all parts impact-proof using suitable material.</li> <li>• Transport and handle the packaging according to the markings (observe lifting gear attachment points, the centre of gravity and orientation e.g. keep vertical, do not throw etc.).</li> <li>• Use proper means of transport and lifting equipment that is in proper working order.</li> <li>• Always adhere to the specified transport and storage parameters.</li> <li>• Store the operating material only outside of areas exposed to direct sunlight and heat sources.</li> </ul>

**Permissible storage and transport conditions, refer to “4.8 Maintenance sticker for filter element replacement” on Page 20.**

<b>NOTE</b>	<b>Handling packaging material!</b>
	<p>Inappropriate disposal of packaging materials can cause environmental damage.</p> <ul style="list-style-type: none"> <li>• The packaging material is recyclable.</li> <li>• Dispose of the packaging material in accordance with the regional laws, provisions, guidelines and regulations of the country and place of use.</li> </ul>

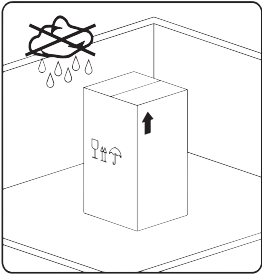
<b>NOTE</b>	<b>Note for transport and storage!</b>
	<p>The operating material must be</p> <ul style="list-style-type: none"> <li>• stored in the original packaging and retained in a dry as well as frost-free room. The ambient conditions, transport and storage parameters must never fall short of/exceed the specifications in the technical data chapter.</li> <li>• Always protect it against external weathering effects even in a packaged condition.</li> <li>• Secure the plant so that it cannot topple over or fall and protect it against vibration at the storage location.</li> </ul>

## 4. Product information

### 4.1 Product description

CLEARPOINT® 3eco coalescing filters are used for the filtration of aerosols and solid particles in compressed gas systems.

Depending on the requirements, filter elements with different filtration stages can be used to achieve the required compressed air class in accordance with ISO 8573-1.

The condensate accumulated during filtration can be discharged manually or automatically.

### 4.2 Product overview

The filter is made up of the following components:

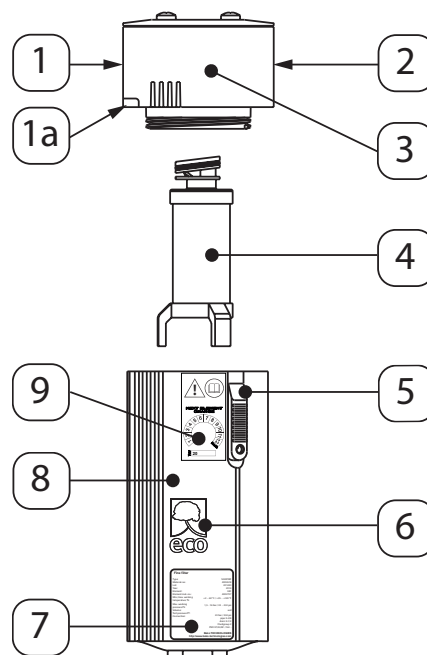

Position no.	Explanation/description
[1]	Inlet at the filter head, additionally marked 1a
[2]	Outlet at the filter head
[3]	Filter head
[4]	Filter element
[5]	Safety slide with locking screw
[6]	eco label: Products with this sticker have special added value in the form of energy saving and are allocated to the eco line of BEKO TECHNOLOGIES GMBH products.
[7]	Type plate
[8]	Filter housing with internal sealing ring
[9]	Maintenance sticker for filter element replacement

### 4.3 Product identification

The product designation is shown on the type plate and made up of numbers and letter codes. Each code stands for a filter component and is divided into the following categories:

- [1] = Size: Housing
- [2] = Filter elements
- [3] = Attachment components top
- [4] = Attachment components bottom

The product designation is explained below using the example “S040CWF”:

1
2
3
4  
**S040CWF**

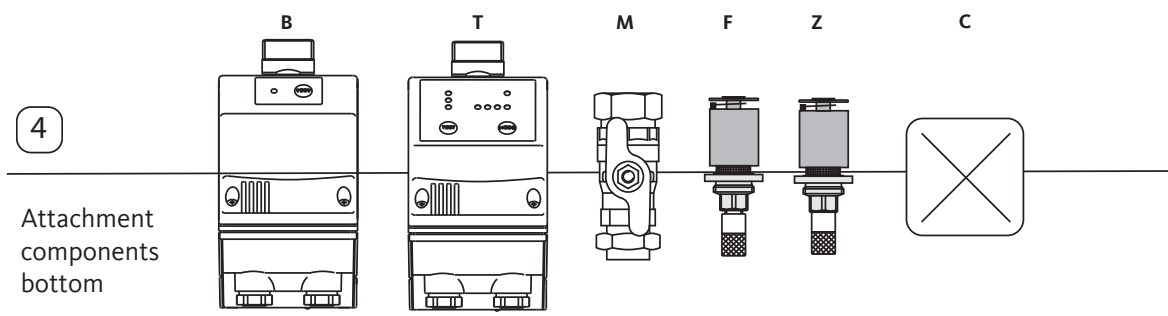
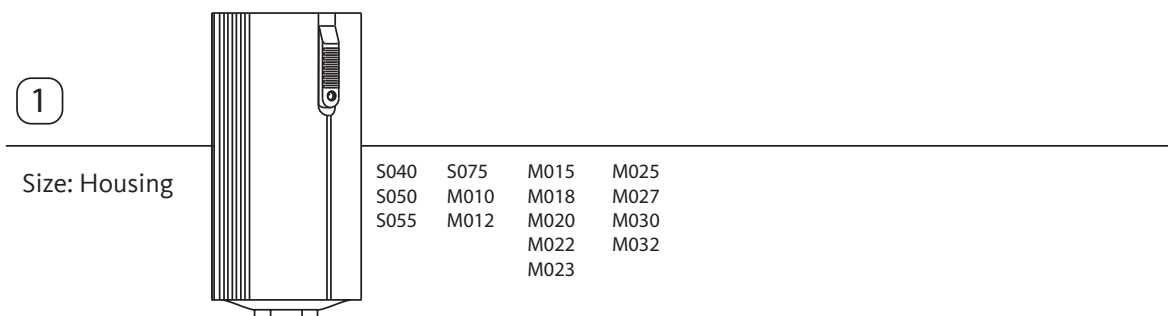
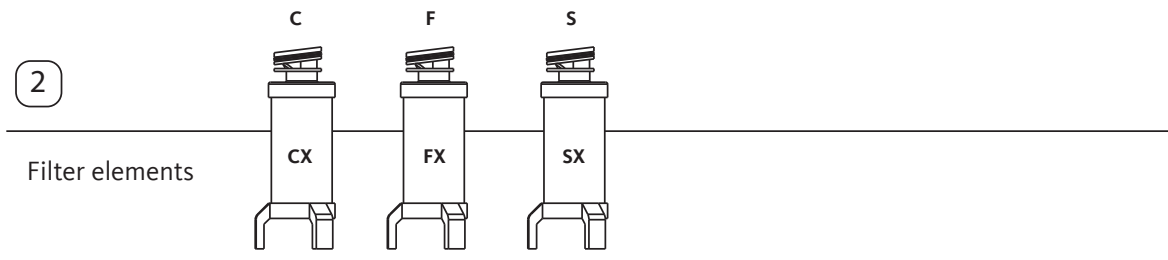
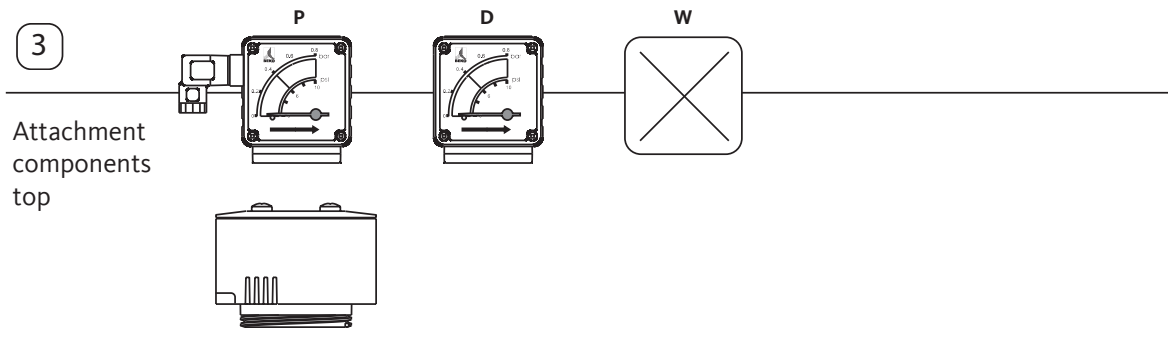

Attachment components top		
Position no.	Letter code	Designation
[3]	P	Differential pressure gauge with potential-free contact
	D	Differential pressure gauge without potential-free contact
	W	Without indicator unit

Filter elements					
Position no.	Letter code	Designation	99.9% separation rate solid particles [µm]	Residual oil content [mg/m <sup>3</sup> ]	Compressed air class in acc. with (ISO 8573 - 1)
[2]	CX	Coarse filter	2 ... 5	≤ 5	[4: - :4]
	FX	Fine filter	0.5 ... 1	≤ 0.05	[2: - :2]
	SX	Super fine filter	0.1 ... 0.3	≤ 0.005	[1: - :2]* <sup>1</sup>

\*<sup>1</sup> Depending on the ambient conditions and operating parameters, class [1: - :1] can also be reached.

Position no.	Model series	Construction size	Designation
[1]	S	040	Filter housing
	S	050	
	S	055	
	S	075	
	M	010	
	M	012	
	M	015	
	M	018	
	M	020	
	M	022	
	M	023	
	M	025	
	M	027	
	M	030	
	M	032	

Attachment components bottom		
Position no.	Letter code	Designation
[4]	B	BEKOMAT® 20
	T	BEKOMAT® 20 FM
	M	Manual condensate drain
	F	Float drain, open when pressureless (NO - normally open)
	Z	Float drain, closed when pressureless (NO - normally closed)
	C	Without condensate drain

## 4.4 Function description

### 4.4.1 Filtration

With the CLEARPOINT® 3eco coalescing filter, the medium flows through the filter element from the inside to the outside. Compressed gas flows into the filter element from where it flows through the filter element into the filter vessel. During this process, particles as well as oil and water aerosols are separated by the filter material. The liquid components in the filter material move downwards due to gravity, drip off and collect at the base of the filter vessel. From there, they are drained off automatically or manually. Over time, particles become deposited in the filter material. This results in an increase in flow resistance (differential pressure) of the filter element.

The particle charge or degree of pollution of the filter element can be read off using a differential pressure gauge. More detailed information about this can be found in the installation and operation manual enclosed with the differential pressure gauge.

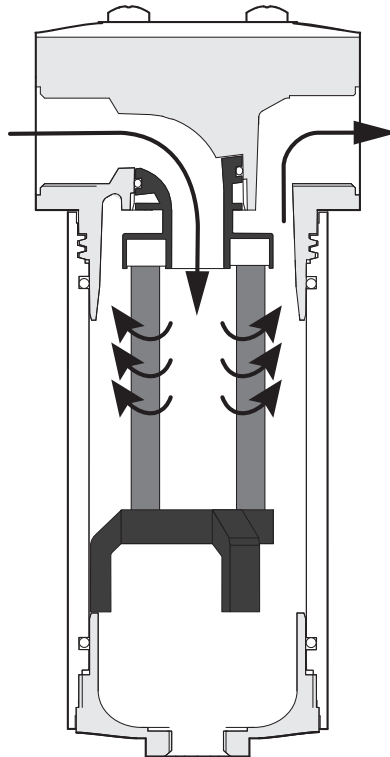



### 4.4.2 Condensate discharge through float drain

Float drains are mechanical condensate drains that work automatically as they are closed and opened based on the buoyancy of a float body [1]. When the condensate [2] in the vessel rises to a certain level, buoyant force pushes the float body [1] up and opens the outlet channel [3] for the condensate. The float body closes again when the condensate [1] drops to below a certain level. A small amount of condensate remains in the vessel.

Two different float drains are used for discharging the condensate:

- Open when pressureless ([NO] normally open) - at operating pressure ≤ 0.5 bar(g) the float drain opens
- Closed when pressureless ([NC] normally closed) - the float drain remains closed even at operating pressure 0 bar(g)

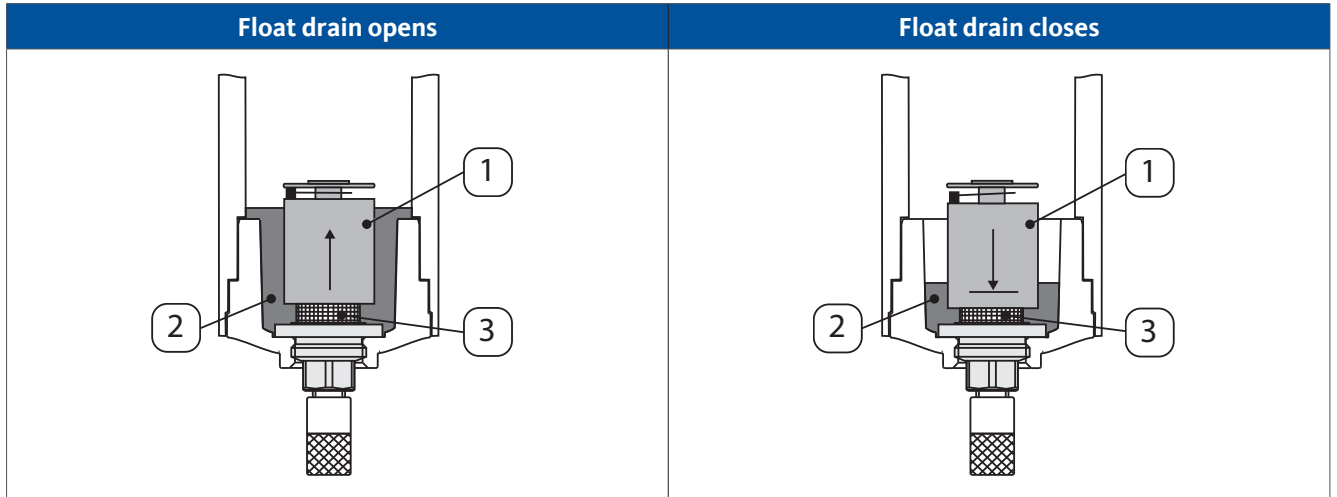

Both types of drain are delivered with the position »Automatic discharge« from the factory. The knurled screw is screwed downwards as far as it will go.

To test the discharge function or relieve the pressure on the filter during maintenance work, the float drain can be set to the position »mechanically open«. Screw the knurled screw anti-clockwise (left-hand thread) upwards as far as it will go.



<b>INFORMATION</b>	<b>Condensate discharge!</b>
	Condensate discharge depends on the product combination and can vary.



For further information on possible product combinations see “4.3 Product identification” on Page 14.

### 4.4.3 Condensate discharge through BEKOMAT

Condensate discharge can also take place via the automatic BEKOMAT® condensate discharge. More detailed information can be found in the installation and operation manual for the BEKOMAT®.

### 4.5 Scope of delivery

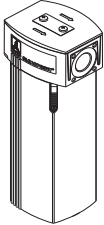
The following table shows the scope of delivery of the filter.

Figure	Description/Explanation
	Filter
	Installation and operation manual

INFORMATION	Possible product combinations!
	The scope of delivery can vary depending on the product combination.

For further information on possible product combinations see “4.3 Product identification” on Page 14.

## 4.6 Type plate

The type plate contains the identification and operating parameters of the filter and is located on the housing. If you contact the manufacturer or supplier, always have this data ready for system identification.

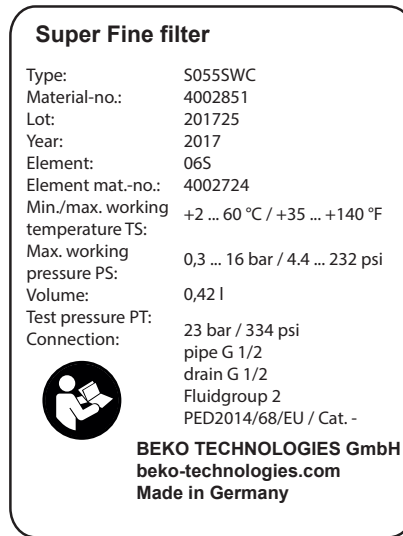

Example:

Position on rating plate	Description
<b>Super Fine Filter</b>	BEKO filter designation
<b>Model:</b>	Sales designation
<b>Material no.</b>	Material number
<b>Lot</b>	Lot number
<b>Year</b>	Year of manufacturer
<b>Element</b>	Filter element type
<b>Element mat-no.:</b>	Filter element material number
<b>Min./max. working temperature TS</b>	Min./max. operating temperature range
<b>Max.working pressure PS</b>	Max. working pressure range
<b>Volume</b>	Housing volume
<b>Test pressure PT</b>	Test pressure
<b>Connection</b>	Thread connections
<b>pipe G 1/2</b>	Thread connection of supply pipe
<b>drain G 1/2</b>	Thread connection of condensate drain
<b>Fluidgroup 2</b>	Fluid group according to Pressure Equipment Directive 2014/68/EU
<b>PED2014/68/EU / Cat. -</b>	Specification of the category according to Pressure Equipment Directive 2014/68/EU

NOTE	Handling the type plate!
	Never damage, remove or make the type plate illegible.

For more information regarding the symbols printed on the type plate, see “1.4 Explanation of the symbols and pictograms utilised” on Page 5.

### 4.7 Filter element sticker

The filter element can be identified on the basis of a sticker on the base of the filter element. There are different filter elements for different applications and degrees of filtration.

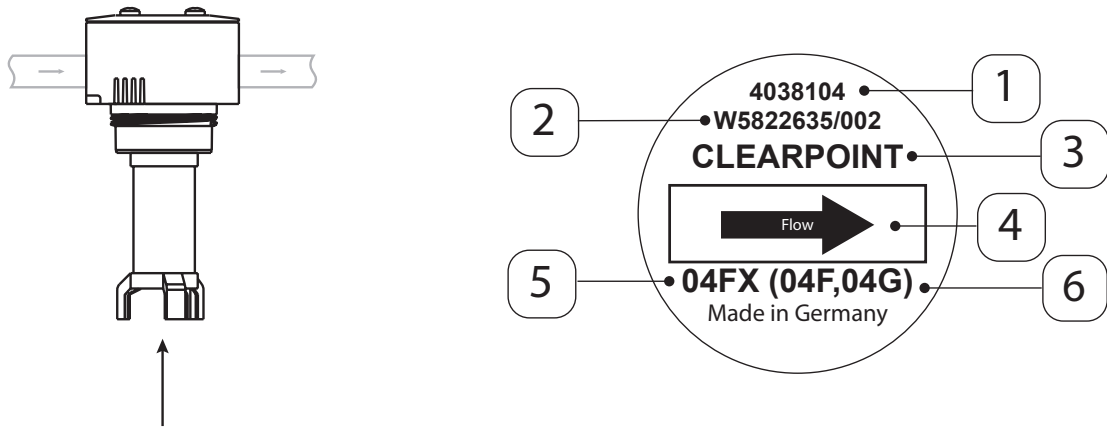

Sticker on the base of the filter element

Filter element sticker  
View filter element base

Position no.	Explanation/description
[1]	Order number
[2]	Lot number
[3]	Product group
[4]	Direction of flow
[5]	04FX designation of the filter element
[6]	04F, 04G designation of predecessor filter element in brackets

### 4.8 Maintenance sticker for filter element replacement

The next due filter element replacement date is entered on this sticker. For this, mark the respective month [1] and enter the year accordingly [2].

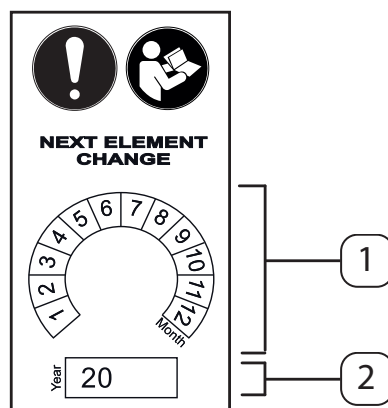

Position no.	Explanation/description
[1]	Specification of month for next filter element replacement
[2]	Specification of year for next filter element replacement

## 5. Technical data

### 5.1 Filter performance data

CLEARPOINT® 3eco		S040	S050	S055	S075	M010	M012	M015
Connection [inches]		3/8	1/2	1/2	3/4	1	1	1 1/2
Volume flow at 7 bar(g) energy-optimised [m <sup>3</sup> /h] <sup>*1</sup>		35	65	100	150	200	250	320
Differential pressure [mbar] (wet saturated)	CX	Ø 50						
	FX	80	115	150	105	120	165	80
	SX	100	125	170	120	135	180	100
Volume flow at 7 bar(g) performance-oriented [m <sup>3</sup> /h] <sup>*1</sup>		46	85	130	195	260	325	415
Differential pressure [mbar] (wet saturated)	CX	Ø 70						
	FX	105	160	230	150	180	230	110
	SX	125	170	255	175	200	260	130
Category according to PED 2014/68/EU		-	-	-	-	-	-	-
Min./max. operating pressure [bar(g)]		0 ... 16						
Min./max. operating temperature [°C]		+2 ... +60						
Load test according to AD2000		10000 load changes $\Delta$ pressure difference $\geq$ 3.2 bar at 16 bar(g)						
Medium		Compressed gases of fluid group 2 according to PED 2014/68/EU free of aggressive and corrosive components						
Weight [kg]		0.75	0.85	1.2	1.7	2.1	2.2	4.1
Volume [l]		0.25	0.31	0.42	0.87	1.12	1.26	2.52

\*1 Volume flow at 7 bar(g) referring to +20 °C and 1 bar(abs)

CLEARPOINT® 3eco		M018	M020	M022	M023	M025	M027	M030	M032	
Connection [inches]		1 1/2	2	2	2	2 1/2	2 1/2	3	3	
Volume flow at 7 bar(g) energy-optimised [m³/h] *1		420	600	780	1020	1300	1620	1940	2400	
Differential pressure [mbar] (wet saturated)	CX	Ø 50								
	FX	90	120	150	200	100	115	120	145	
	SX	110	140	170	210	125	130	140	165	
Volume flow at 7 bar(g) performance-oriented [m³/h] *1		545	780	1015	1325	1690	2100	2520	3120	
Differential pressure [mbar] (wet saturated)	CX	Ø 70								
	FX	125	180	210	290	140	155	180	220	
	SX	150	210	250	320	170	185	210	250	
Category according to PED 2014/68/EU		-	I	I	I	II	II	II	II	
Min./max. operating pressure [bar(g)]		0 ... 16								
Min./max. operating temperature [°C]		+2 ... +60								
Load test according to AD2000		10000 load changes $\Delta$ pressure difference $\geq 3.2$ bar at 16 bar(g)								
Medium		Compressed gases of fluid group 2 according to PED 2014/68/EU free of aggressive and corrosive components								
Weight [kg]		4.5	5.1	6.1	7.1	19.9	22.6	25.9	29.9	
Volume [l]		2.97	3.40	4.23	5.24	13.9	16.5	19.5	23.2	

\*1 Volume flow at 7 bar(g) referring to +20 °C and 1 bar(abs)

## 5.2 Filter element performance data

The performance data of the filter elements refer to validation according to ISO 12500-1 and -3.

Model	Description	Solid particles [µm]	Aerosol content [mg/m³]	
			Inlet	Output
CX	Coarse filter	Separation rate 99.9 % for particles 2.0 - 5.0	30	5
FX	Fine filter	Separation rate 99.9 % for particles 0.5 - 1.0	10	0.05
SX	Super fine filter	Separation rate 99.99 % for particles 0.1 - 0.3	10	0.005

### 5.3 Materials

Component	Material
Housing head (filter head)	S040 ... M012: Aluminium (die-cast), anodised, powder-coated M015 ... M032: Aluminium (sand-cast), anodised, powder-coated
Housing body	S040 ... M032: Aluminium (extruded profile), anodised, powder-coated
Housing cover	Polyamide PA6, 30 % glass fibre reinforced
Housing base	S040 ... M012: Aluminium (die-cast), anodised, powder-coated M015 ... M032: Aluminium (sand-cast), anodised, powder-coated
M5 screws	Steel, black galvanised
Slide	Zinc (die-cast), seal FKM
O-rings	Standard: NBR   oil-free: FKM
Float drain-off conduit	Plastic   brass   NBR
Manual drain	Brass, nickel-plated
Wall bracket	Stainless steel
Sticker	Soft PVC, polyacrylate adhesive
BEKOMAT®	See the installation and operating manual for the BEKOMAT®
Differential pressure gauge	See the installation and operating manual for the differential pressure gauge
Oil indicator	See the installation and operating manual for the oil indicator
Filter element	Element head and base = Polyamide PA6, 30 % glass content Support body inside / outside = Expanded stainless steel Non-woven filter material = Borosilicate fibres Support material for pleats = Polypropylene Drainage material = Polyester needle felt Sealing compound = Polyurethane O-rings = Standard: NBR   oil-free: FKM

## 6. Dimensions

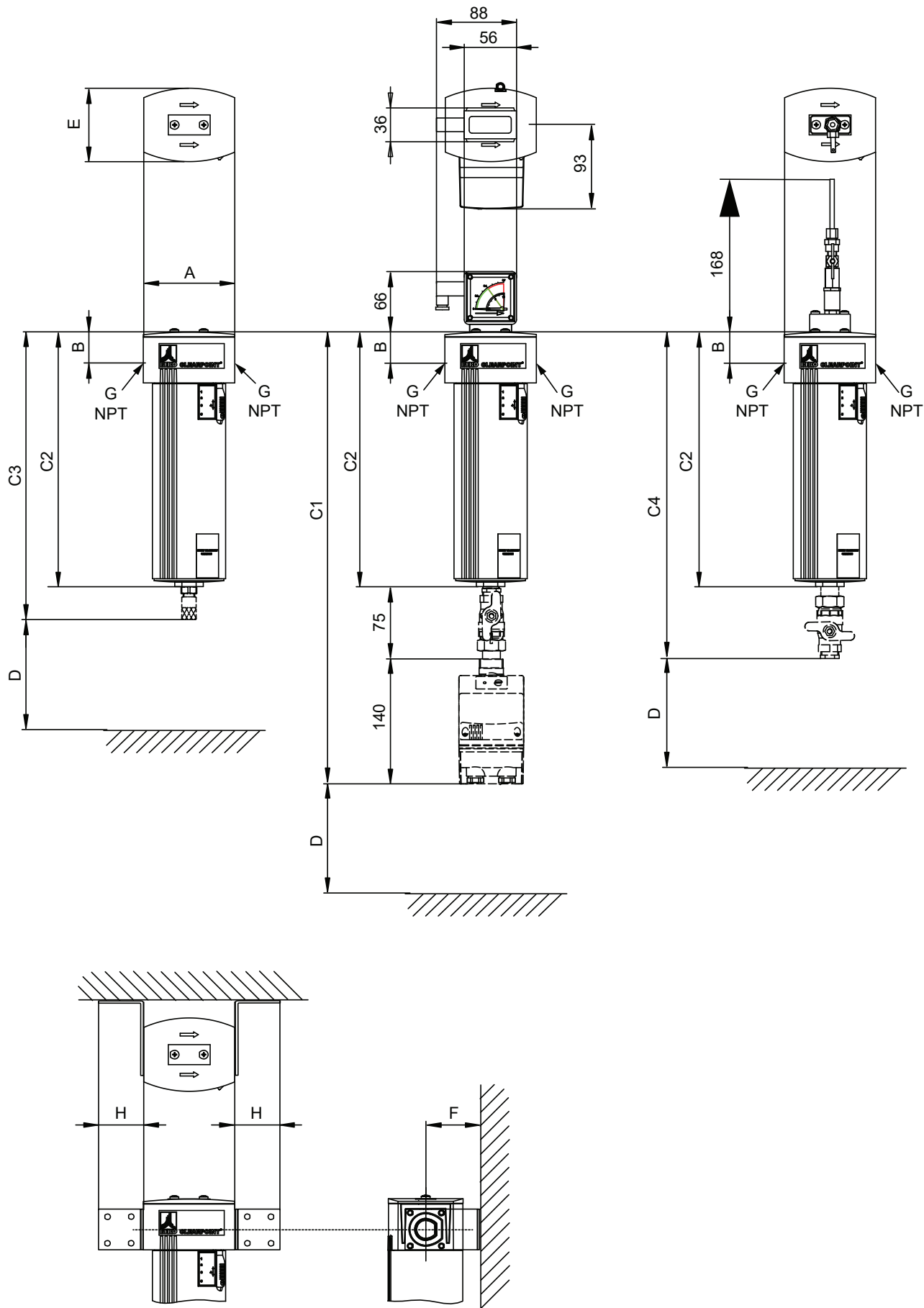







Filter	Connection thread	A	B	C1	C2	C3	C4	D	E	F	H	Filter element
	G / NPT [inches]	[mm]	[mm]	[mm]	[mm]	[mm]	[mm]	[mm]	[mm]	[mm]	[mm]	*1
S040 (type)	3/8	75	28	395	180	208	243	150	60	64.5	39.5	04 (type)
S050 (type)	1/2	75	28	425	210	238	273	150	60	64.5	39.5	05 (type)
S055 (type)	1/2	75	28	480	265	293	328	150	60	64.5	39.5	06 (type)
S075 (type)	3/4	100	34	495	280	308	343	150	80	63	45	07 (type)
M010 (type)	1	100	34	565	350	378	413	150	80	63	45	10 (type)
M012 (type)	1	100	34	600	385	413	448	150	80	63	45	12 (type)
M015 (type)	1 1/2	146	48	580	365	384	428	200	120	78.5	60	15 (type)
M018 (type)	1 1/2	146	48	633	418	437	481	200	120	78.5	60	18 (type)
M020 (type)	2	146	48	683	468	487	531	200	120	78.5	60	20 (type)
M022 (type)	2	146	48	780	565	584	628	200	120	78.5	60	22 (type)
M023 (type)	2	146	48	898	683	702	746	300	120	78.5	60	23 (type)
M025 (type)	2 1/2	260	77	886	671	684	734	300	200	130	120	25 (type)
M027 (type)	2 1/2	260	77	990	775	788	838	300	200	130	120	27 (type)
M030 (type)	3	260	77	1010	895	908	958	300	200	130	120	30 (type)
M032 (type)	3	260	77	1260	1045	1058	1108	300	200	130	120	32 (type)

\*1 Please state the degree of filtration (type) with your order!

## 7. Assembly

### 7.1 Warning

<b>DANGER</b>	<b>Use of incorrect spare parts, accessories or installation materials!</b>
	<p>The use of incorrect spare parts, accessories or installation materials, as well as auxiliary and operating materials, may result in death or serious injury. In addition, functional and operational malfunctions or material damage can occur.</p> <ul style="list-style-type: none"> <li>• For all installation, servicing and maintenance work, only use undamaged original parts, auxiliary and operating materials which are specified by the manufacturer.</li> <li>• Only use fittings and connecting elements approved for the respective application as well as suitable tools in perfect operating condition.</li> <li>• Only use pipes that are free of dirt, damage and corrosion.</li> </ul>
<b>DANGER</b>	<b>Pressurised system!</b>
	<p>Death or serious personal injury can result through contact with fast or suddenly escaping compressed air or through bursting system parts</p> <ul style="list-style-type: none"> <li>• All work on the system must be carried out in the depressurised state and with the system secured against unintentional pressure build-up.</li> <li>• Set up a safety zone around the system during all assembly, installation, maintenance and repair work.</li> <li>• Before applying pressure to the system, check all pipe connections and tighten if necessary.</li> <li>• Slowly pressurise the system with compressed gas.</li> <li>• Avoid pressure blows and high differential pressures.</li> <li>• Assemble all pipes without mechanical stress. Avoid any vibrations occurring in the pipe network by using vibration dampers.</li> <li>• The pipes must be able to bear the additional weight of the filter. Additional fixings must be mounted if necessary.</li> <li>• Always keep exactly to the installation and operating instructions given in this manual.</li> <li>• Always keep inspection and maintenance interval exactly.</li> <li>• Install fixed pipes as supply and discharge pipes.</li> <li>• Do not carry out any structural changes to the product.</li> </ul>
<b>WARNING</b>	<b>Insufficient qualification!</b>
	<p>Insufficient qualification of the personnel can lead to accidents, personal injury and damage to the device as well as impairments during work on the operating material.</p> <p>All work on the product may only be carried out by appropriately qualified skilled personnel.</p>
<b>CAUTION</b>	<b>Inappropriate assembly!</b>
	<p>Inappropriate assembly of the product can lead to personal injury and product damage as well as impair operation.</p> <ul style="list-style-type: none"> <li>• The direction of flow of the filter must match the direction of flow in the pipe.</li> <li>• The filter must be fitted vertically in the pipe.</li> </ul>

## 7.2 Assembly work

For assembly work to be carried out, the following prerequisites must be fulfilled and the preparatory tasks must have been completed.

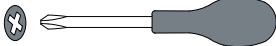
Prerequisites		
Tools	Material	Protective equipment
<ul style="list-style-type: none"> <li>Screwdriver - cross-head size 2.5 mm</li> </ul> 	<ul style="list-style-type: none"> <li>Additional installation and operating manual for the accessories used</li> <li>Sealing materials such as e.g. PTFE tape (EN 837-2)</li> </ul>	<ul style="list-style-type: none"> <li>Protective gloves (fluid-resistant)</li> <li>Safety goggles with side shields</li> <li>Hearing protection</li> <li>Respiratory protection, protection class FFP 3</li> <li>Safety footwear</li> </ul>

Preparation of installation	
1.	Remove the dust cap from the following threads: <ul style="list-style-type: none"> <li>Inlet and outlet on the filter head</li> <li>Condensate drain on the filter base</li> </ul>
2.	Depressurise the pipelines or relevant pipe section.
3.	Heed the filter dimensions and make sure there is sufficient space for assembly. See "6. Dimensions" on Page 24.
4.	Pipes must be able to bear the additional weight of the filter. Additional fixings must be mounted if necessary.
5.	Pipes must be free of contamination and corrosion. Check pipe thread for damage. Defective pipes must be replaced immediately.
6.	Pipes must be free of mechanical stress and corrosion. Compensate any vibrations which occur by using vibration dampers.
7.	Only use fittings which are suitable for this pressure and temperature range. The pipe threads must match those of the filter head.
8.	Execute the condensate drain in such a way that no compressed gas or condensate can escape to the surrounding of the filter. The condensate to be discharged should be routed to a treatment system conforming to law (e.g. ÖWAMAT® or BEKOSPLIT®).

The direction of flow of the filter must be taken into account during assembly. It must be adapted to the direction of flow in the pipe.

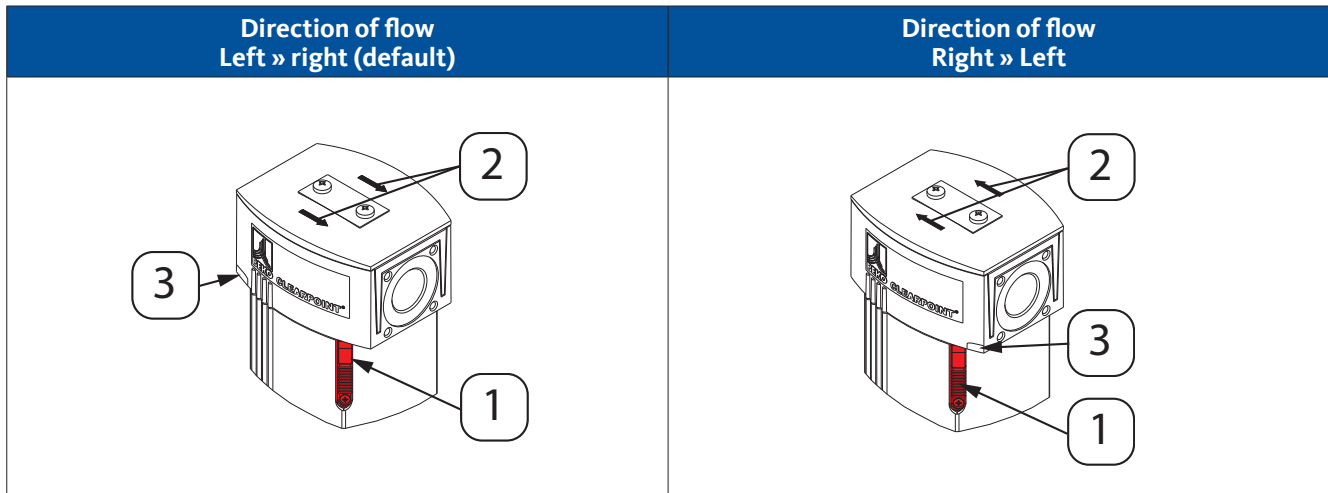

The housing head and the housing body are equipped with a double-start trapezoidal thread. The direction of flow of the filter can be adapted to the direction in the pipe by turning the housing head through 180°. The direction of flow is indicated by arrows [2] and a raised marking [3] on the housing head. These must be aligned as shown. The safety slide [1] must always be in an easily accessible position on the front.

The fitting of a bypass pipe [4] and corresponding shut-off valves [5] is recommended for maintenance and servicing work.

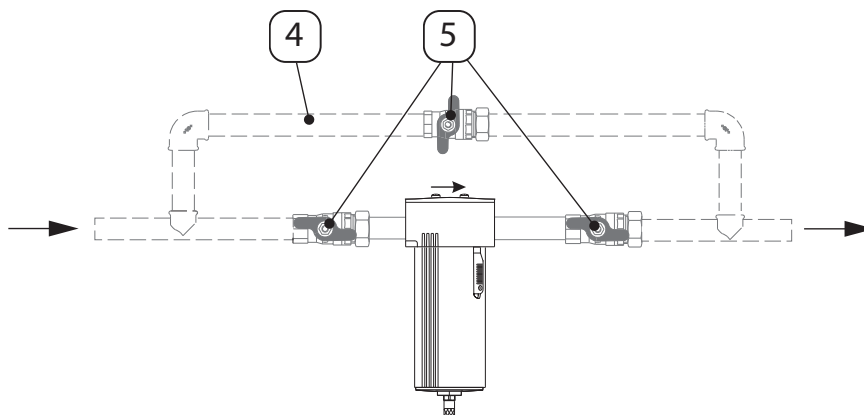

1. Apply sealing material e.g. PTFE-tape (EN 837-2) to the pipe ends
2. Screw the pipe thread into the filter inlet until the connection is firm and leak-tight
3. Screw the pipe thread into the filter outlet until the connection is firm and leak-tight

After assembly work has been finished, it must be checked whether the housing body has been screwed in properly, the safety slide pushed up and the safety screw tightened hand-tight. A leakage test should be carried out to check the assembly work. For additional information, refer to “9.6 Leakage test” on Page 39.

## 8. Commissioning

### 8.1 Commissioning tasks

For commissioning to be carried out, the following prerequisites must be fulfilled and the preparatory tasks must have been completed.

Prerequisites		
Tools	Material	Protective equipment
<ul style="list-style-type: none"> <li>• none</li> </ul>	<ul style="list-style-type: none"> <li>• none</li> </ul>	<ul style="list-style-type: none"> <li>• None</li> </ul>

Preparation of installation	
1.	Assembly finished including subsequent leakage test

Figure		Description
Automatic discharge	Mechanically open	
		<ol style="list-style-type: none"> <li>1. Set the knurled screw on the float drain from <b>&gt;&gt;Mechanically open&lt;&lt;</b> anti-clockwise (left-hand thread) to <b>&gt;&gt;Automatic discharge&lt;&lt;</b></li> </ol>

Figure	Description
	<ol style="list-style-type: none"> <li>2. Open the shut-off valve <b>[1]</b> on the inlet side <b>slowly</b></li> <li>3. Open the shut-off valve <b>[2]</b> on the outlet side <b>slowly</b></li> <li>4. Close the shut-off valve <b>[3]</b> of the bypass pipe</li> </ol>

## 9. Maintenance and servicing

### 9.1 Maintenance schedule

Maintenance	Interval
Cleaning work	At regular intervals, depending on the degree of contamination
Visual inspection	Weekly
Replace the float drain	Annually
Replace the filter element	Annually or with a differential pressure $\geq 0.4$ bar
Leakage test	Recommended interval: At the end of all assembly work and maintenance and servicing work on the product

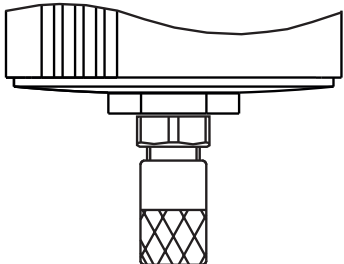
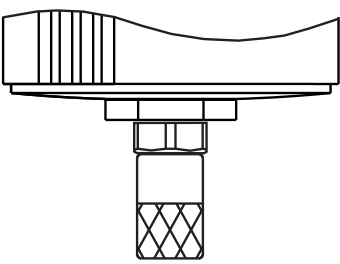
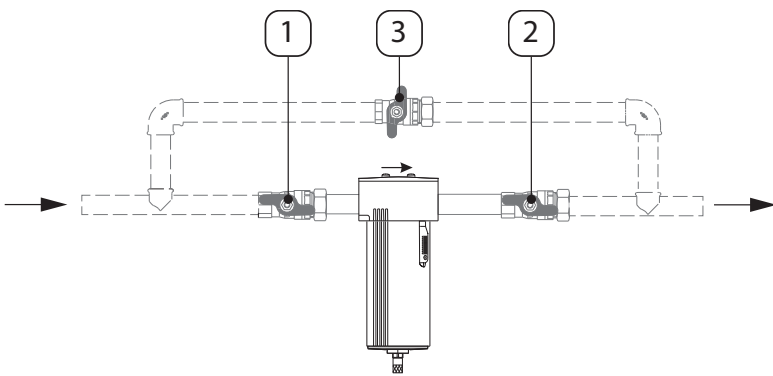
### 9.2 Cleaning

#### 9.2.1 Warning

CAUTION	Inappropriate cleaning and use of the wrong cleaning media!
	<p>Inappropriate cleaning and the use of the wrong cleaning media may result in minor injuries as well as damage to health and property.</p> <ul style="list-style-type: none"> <li>• Never clean the device with a wet cloth.</li> <li>• Never use abrasive or aggressive cleaning agents or solvents which could damage the outer coating (e.g. labels, type plate, corrosion protection, etc.).</li> <li>• Never clean the device with hard or pointed implements.</li> <li>• For external cleaning, use a dust brush or damp cotton cloths that cannot become statically charged.</li> <li>• Immediately replace operating material labels (pictograms, labels) that have become illegible.</li> </ul>

NOTE	Local hygiene regulations!
	<p>In addition to the cleaning instructions listed, any local hygiene regulations which are in place must be heeded.</p>

## 9.2.2 Cleaning work

For cleaning to be carried out, the following prerequisites must be fulfilled and the preparatory tasks must have been completed.

Prerequisites		
Tools	Material	Protective equipment
<ul style="list-style-type: none"> <li>None</li> </ul>	<ul style="list-style-type: none"> <li>Mild detergent</li> <li>Cotton cloth or disposable tissue</li> </ul>	<ul style="list-style-type: none"> <li>Protective gloves (fluid-resistant)</li> <li>Safety goggles with side shields</li> <li>Hearing protection</li> <li>Respiratory protection, protection class FFP 3</li> <li>Safety footwear</li> </ul>

To clean the filter, use a damp (but not wet) cotton cloth or disposable tissue and a mild conventional detergent or soap.

1. Spray a little detergent onto the clean cotton cloth or disposable tissue.
2. Wipe down the entire surface of the component.
3. Then dry using a clean cloth or let it dry at room temperature.

## 9.3 Visual inspection

During the visual inspection of the filter, all components must be inspected for mechanical damage and corrosion. Any damaged components must be replaced immediately.

### 9.4 Replace the float drain

For float drain replacement to be carried out, the following prerequisites must be fulfilled and the preparatory tasks must have been completed.

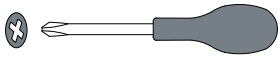
Prerequisites		
Tools	Material	Protective equipment
<ul style="list-style-type: none"> <li>Screwdriver - cross-head size 2.5 mm</li> </ul> 	<ul style="list-style-type: none"> <li>New float drain with adapter enclosed</li> </ul>	<ul style="list-style-type: none"> <li>Protective gloves (fluid-resistant)</li> <li>Safety goggles with side shields</li> <li>Hearing protection</li> <li>Respiratory protection, protection class FFP 3</li> <li>Safety footwear</li> </ul>

Preparation of installation	
1.	Open the bypass pipe if available

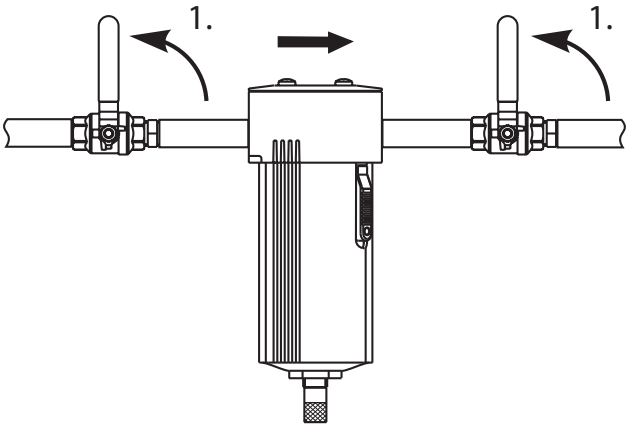
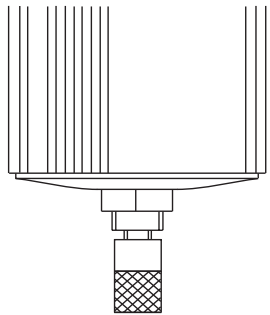
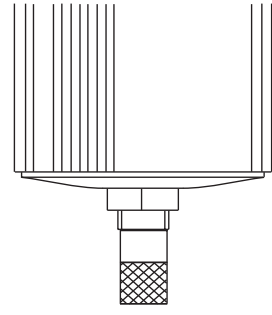
Figure	Description
	<p>1. Close the shut-off valves upstream and downstream of the filter or the respective system section</p>
<div style="display: flex; justify-content: space-around;"> <div style="text-align: center;">  <p>2. ↻</p> <p>Automatic discharge</p> </div> <div style="text-align: center;">  <p>Mechanically open</p> </div> </div>	<p>2. Set the knurled screw on the float drain anti-clockwise (left-hand thread) from &gt;&gt;Automatic discharge&lt;&lt; to &gt;&gt;Mechanically open&lt;&lt;</p>



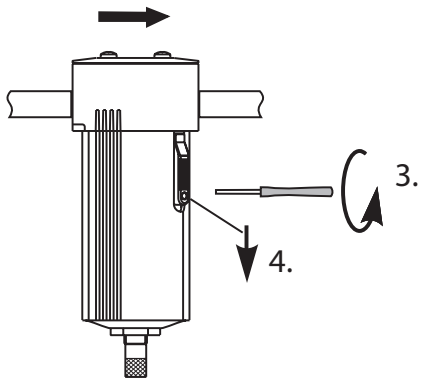

- 3. Undo the locking screw on the safety slide
- 4. Push the safety slide downwards

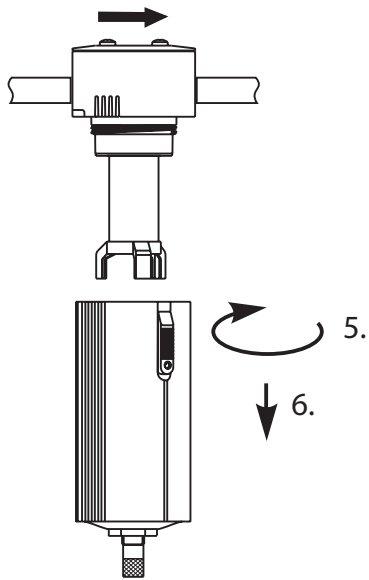

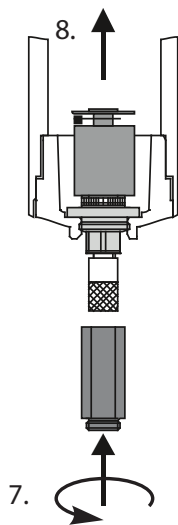

- 5. Unscrew the housing body
- 6. Pull the housing body down and off

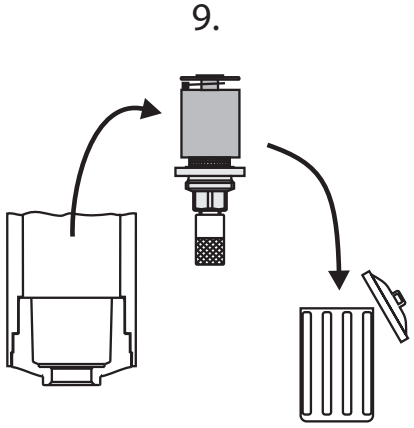
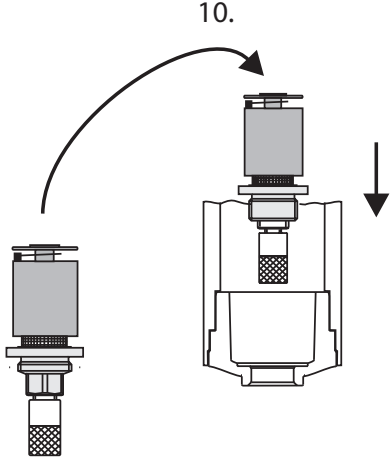
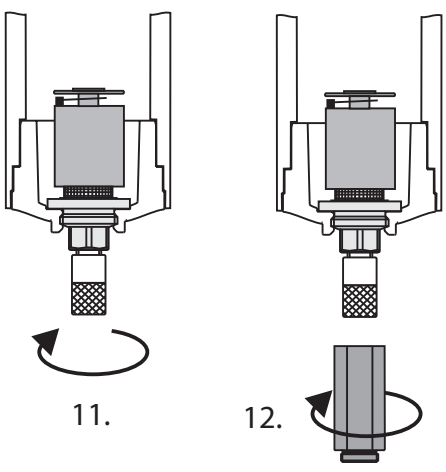

- To screw the float drain out, use the size 13 adapter enclosed with the float drain.
- 7. Use the adapter to screw the float drain out anti-clockwise
  - 8. Lift the float drain out of the top of the housing body

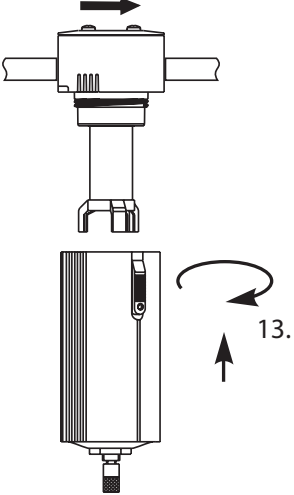
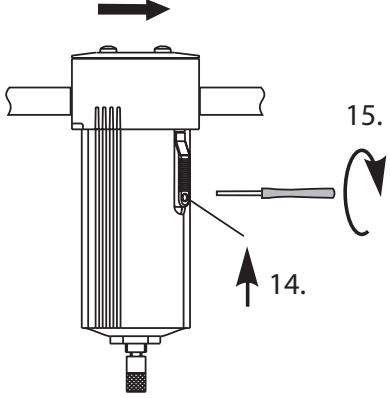
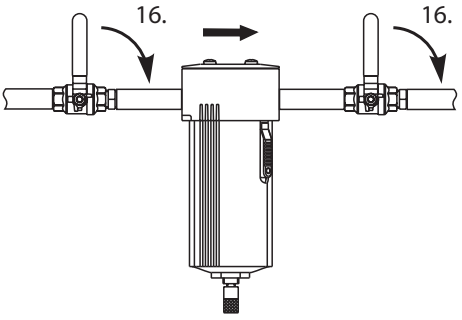
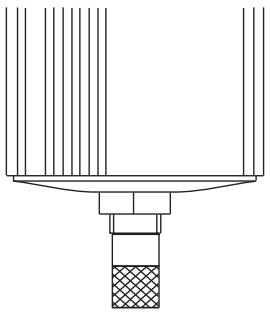
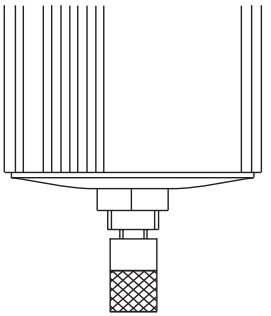
 <p>9.</p>	<p>9. Dispose of the float drain properly and in line with the regional requirements.</p> <p><b>For more information, see “12. Disposal” on Page 44.</b></p>
 <p>10.</p>	<p>10. Insert a new float drain into the housing body</p>
 <p>11.</p> <p>12.</p>	<p>11. Screw the float drain into the housing body clockwise by hand</p> <p>12. Tighten the float drain using the adapter</p>

	<p>13. Screw the housing body back onto the filter head</p> <p><b>Make sure that the safety slide is facing the front after assembly.</b></p>
	<p>14. Push the safety slide upwards</p> <p>15. Tighten the locking screw on the safety slide</p>
	<p>16. Slowly open the shut-off valves upstream and downstream of the filter or the respective system section</p>
<div style="display: flex; justify-content: space-around;"> <div data-bbox="183 1646 454 1960">  <p>Mechanically open</p> </div> <div data-bbox="518 1646 790 1960">  <p>17. </p> <p>Automatic discharge</p> </div> </div>	<p>17. Set the knurled screw on the float drain anti-clockwise (left-hand thread) from <b>&gt;&gt;Mechanically open&lt;&lt;</b> to <b>&gt;&gt;Automatic discharge&lt;&lt;</b> by unscrewing the knurled screw as far as it will go</p>

## 9.5 Replace the filter element

For filter element replacement to be carried out, the following prerequisites must be fulfilled and the preparatory tasks must have been completed.

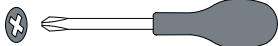
Prerequisites		
Tools	Material	Protective equipment
<ul style="list-style-type: none"> <li>Screwdriver - cross-head size 2.5 mm</li> </ul> 	<ul style="list-style-type: none"> <li>New filter element</li> </ul>	<ul style="list-style-type: none"> <li>Protective gloves (fluid-resistant)</li> <li>Safety goggles with side shields</li> <li>Hearing protection</li> <li>Respiratory protection, protection class FFP 3</li> <li>Safety footwear</li> </ul>

Preparation of installation	
1.	Open the bypass pipe if available

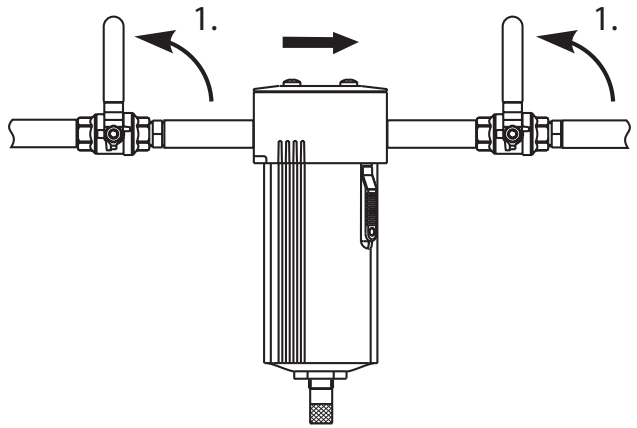
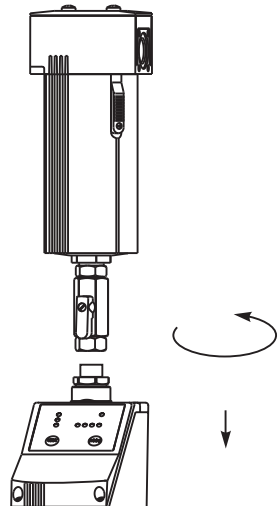
Figure	Description
	<p>1. Close the shut-off valves upstream and downstream of the filter or the respective system section and depressurise the filter</p>
	<p>2. When the BEKOMAT® is used, it must be disconnected from the filter base.</p> <p>For further information see the enclosed installation and operating manual for the BEKOMAT®</p>

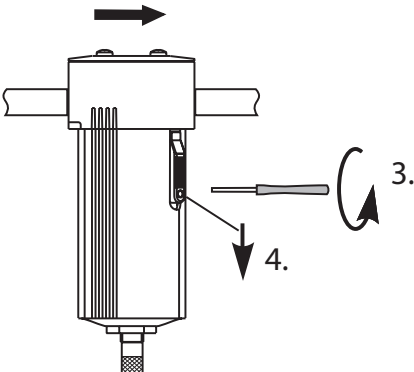
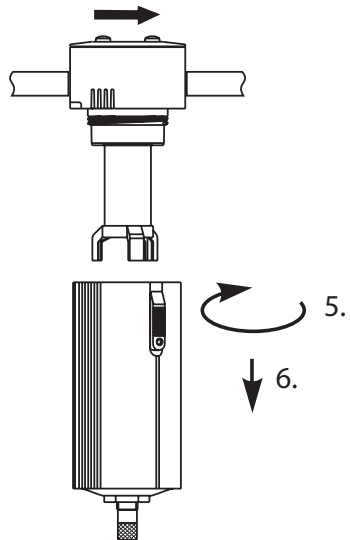
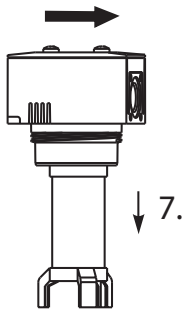
	<p>3. Undo the locking screw on the safety slide 4. Push the safety slide downwards</p>
	<p>5. Unscrew the housing body 6. Pull the housing body down and off</p>
	<p>7. Pull the used filter element down and out of the housing head</p>

	<p>8. Insert a new filter element in the housing head The direction of flow indicated on the housing head and the filter element base must match</p>
	<p>9. Screw the housing body to the housing head <b>Make sure that the safety slide is facing the front.</b></p>
	<p>10. Push the safety slide upwards 11. Tighten the locking screw on the safety slide</p>

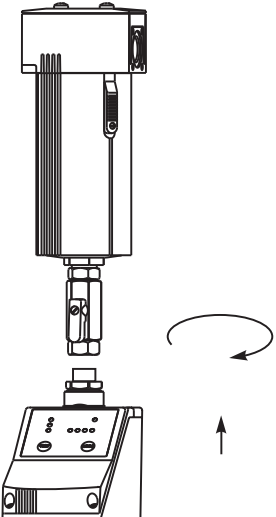
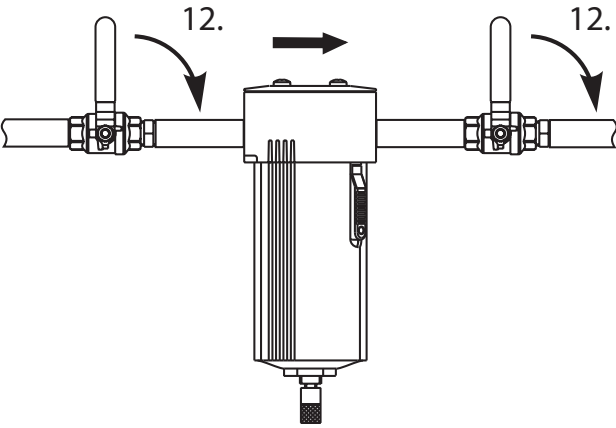
	<p>12. When the BEKOMAT® is used it must be reconnected</p> <p>For further information see the enclosed installation and operating manual for the BEKOMAT®</p>
	<p>13. Slowly open the shut-off valves upstream and downstream of the filter or the respective system section</p>

## 9.6 Leakage test

The leakage test is a non-destructive test method and is used to prove leak tightness in vacuum and overpressure systems. The leakage test can be carried out in different ways. **BEKO TECHNOLOGIES GMBH** does not make a specific recommendation here. The company operating the compressed gas system is responsible for the selection and specification of the test method to be used, which should be carried out in accordance with valid standards and regulations (e.g. DIN EN 1779).

## 10. Shut down

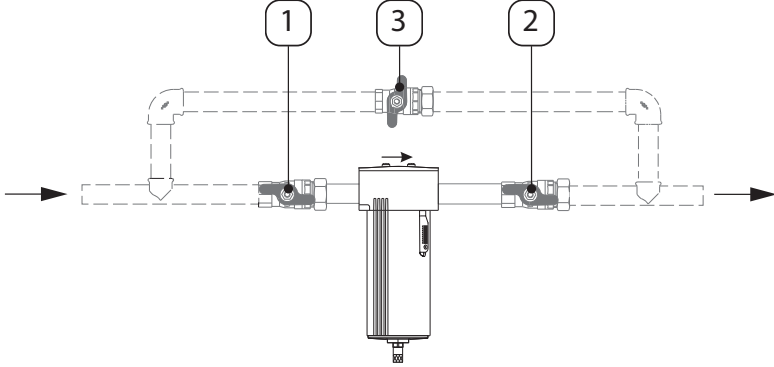
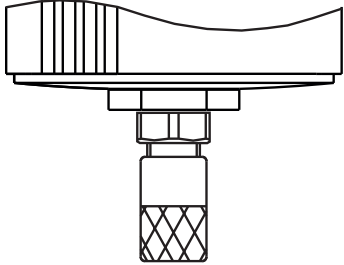
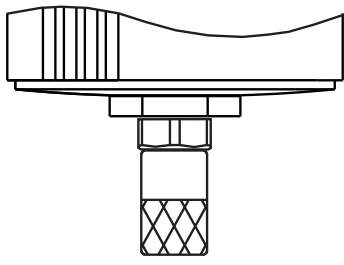



Figure	Description
	<ol style="list-style-type: none"> <li>1. Open the shut-off valve <b>[3]</b> of the bypass pipe (if available)</li> <li>2. Close the shut-off valve <b>[2]</b> on the outlet side</li> <li>3. Close the shut-off valve <b>[1]</b> on the inlet side</li> </ol>

Figure		Description
Automatic discharge	Mechanically open	
		<ol style="list-style-type: none"> <li>4. Set the knurled screw on the float drain anti-clockwise (left-hand thread) from <b>&gt;&gt;Automatic discharge&lt;&lt;</b> to <b>&gt;&gt;Mechanically open&lt;&lt;</b> or press the BEKOMAT® TEST button until the filter is pressureless</li> </ol>



# 11. Disassembly

## 11.1 Warning

<b>DANGER</b>	<b>Use of incorrect accessories, materials or spare parts!</b>
	<p>The use of incorrect spare parts, accessories or installation materials, as well as auxiliary and operating materials, may result in death or serious injury. In addition, functional and operational malfunctions or material damage can occur.</p> <ul style="list-style-type: none"> <li>• For all disassembly work, only use undamaged original parts, auxiliary and operating materials which are specified by the manufacturer.</li> <li>• Only use fittings and connecting elements approved for the respective application as well as suitable tools in perfect operating condition.</li> </ul>
<b>DANGER</b>	<b>Compressed air</b>
	<p>Death or serious personal injury can result through contact with fast or suddenly escaping compressed air or through bursting system parts</p> <ul style="list-style-type: none"> <li>• All work on the system must be carried out in the depressurised state and with the system secured against unintentional pressure build-up.</li> <li>• Set up a safety zone around the system during all assembly, installation, maintenance and repair work.</li> <li>• Before applying pressure to the system, check all pipe connections and tighten if necessary.</li> <li>• Slowly pressurise the system with compressed gas.</li> <li>• Avoid pressure blows and high differential pressures.</li> <li>• Assemble all pipes without mechanical stress. Avoid any vibrations occurring in the pipe network by using vibration dampers.</li> <li>• Always keep exactly to the installation and operating instructions given in this manual.</li> <li>• Always keep inspection and maintenance interval exactly.</li> <li>• Install fixed pipes as supply and discharge pipes.</li> <li>• Do not carry out any structural changes to the product.</li> </ul>
<b>WARNING</b>	<b>Insufficient qualification!</b>
	<p>Insufficient qualification of the personnel can lead to accidents, personal injury and damage to the device as well as impairments during work on the operating material.</p> <p>The work on the product described below may only be executed and documented by qualified personnel for compressed gas technology.</p>

## 11.2 Disassembly work

For disassembly to be carried out, the following prerequisites must be fulfilled and the preparatory tasks must have been completed.

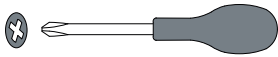
Prerequisites		
Tools	Material	Protective equipment
<ul style="list-style-type: none"> <li>Screwdriver - cross-head size 2.5 mm</li> </ul> 	<ul style="list-style-type: none"> <li>none</li> </ul>	<ul style="list-style-type: none"> <li>Protective gloves (fluid-resistant)</li> <li>Safety goggles with side shields</li> <li>Hearing protection</li> <li>Respiratory protection, protection class FFP 3</li> <li>Safety footwear</li> </ul>

Preparation of installation	
1.	Open the bypass pipe if available

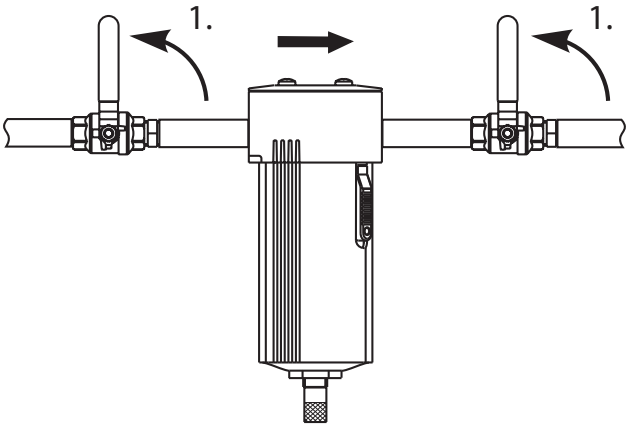
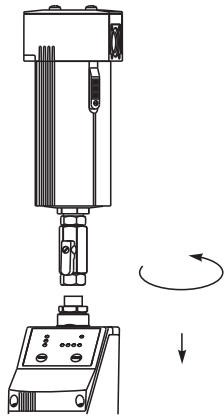

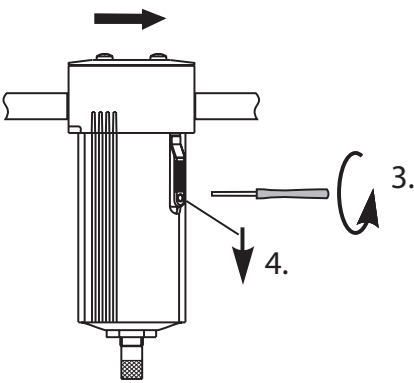
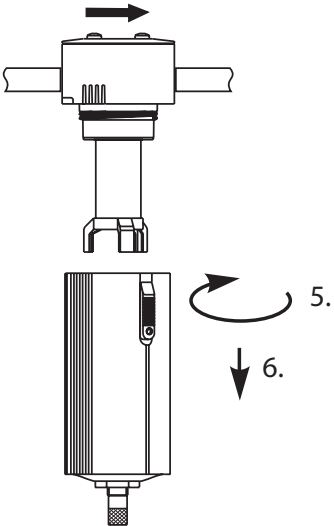
Figure	Description
	<p>1. Close the shut-off valves upstream and downstream of the filter or the respective system section, depressurise the filter and secure the system against unintentional application of pressure</p>
	<p>2. When the BEKOMAT® is used, it must be disconnected from the filter base</p> <p>For further information see the enclosed installation and operating manual for the BEKOMAT®</p>

	<ol style="list-style-type: none"> <li>3. Undo the locking screw on the safety slide</li> <li>4. Push the safety slide downwards</li> </ol>
	<ol style="list-style-type: none"> <li>5. Unscrew the housing body</li> <li>6. Pull the housing body down and off</li> <li>7. Remove the filter element</li> </ol>

8. Remove the filter head from the pipe and seal the ends of the pipe properly
9. Dispose of the component properly

## 12. Disposal

### 12.1 Warning

<b>DANGER</b>	<b>Use of incorrect accessories, materials or spare parts!</b>
	<p>The use of incorrect spare parts, accessories or installation materials, as well as auxiliary and operating materials, may result in death or serious injury. In addition, functional and operational malfunctions or material damage can occur.</p> <ul style="list-style-type: none"> <li>• For all disassembly work, only use undamaged original parts, auxiliary and operating materials which are specified by the manufacturer.</li> <li>• Only use fittings and connecting elements approved for the respective application as well as suitable tools in perfect operating condition.</li> </ul>
<b>NOTE</b>	<b>Inappropriate disposal!</b>
	<p>Inappropriate disposal of parts and components, operating and auxiliary materials as well as cleaning media can cause environmental damage.</p> <ul style="list-style-type: none"> <li>• Dispose of all parts and components, operating and auxiliary materials as well as cleaning media professionally and in accordance with regional legal provisions, regulations and requirements.</li> <li>• In case of uncertainties regarding disposal, always consult a regional waste management company.</li> </ul>

### 12.2 Disposal work

At the end of its useful life, the product must be disposed of properly e.g. by a specialist company. Materials as glass, plastics and some chemical compounds are mostly recoverable, reusable, or recyclable.

All national and local regulations must be kept during disposal.

#### Used filter element:

Waste key: 150203

Adsorption and filter materials; cleaning wipes and protective clothing with the exception of those classified by 150202

#### Used float drain

Do not dispose of as household waste! Disposal must be carried out properly and in line with environmental requirements.

## 13. Spare parts and accessories

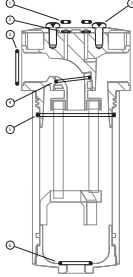

### 13.1 Spare parts

Designation	Figure	Separate documentation
O-ring set for S040, S050, S055 → 4026562 O-ring set for S075, M010, M012 → 4026563 O-ring set for M015, M018, M020, M022, M023 → 4026564 O-ring set for M025, M027, M030, M032 → 4026565		Enclosed instruction leaflet

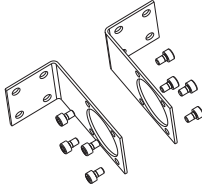
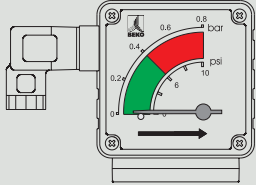
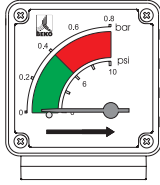
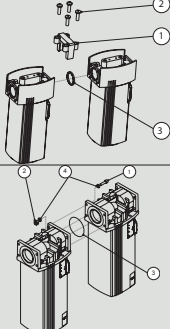
### 13.2 Accessories attachment components top

Designation	Figure	Separate documentation
Wall bracket for S040, S050, S055 → 4003328 Wall bracket for S075, M010, M012 → 4003329 Wall bracket for M015, M018, M020, M022, M023 → 4003330 Wall bracket for M025, M027, M030, M032 → 4003331		None
Differential pressure gauge with potential-free contact → 4001481		Enclosed installation and operation manual
Differential pressure gauge without potential-free contact → 4001491		Enclosed installation and operation manual
Connecting kit for S040, S050, S055 → 403332 Connecting kit for S075, M010, M012 → 403333 Connecting kit for M015, M018, M020, M022, M023 → 403334 Connecting kit or M025, M027, M030, M032 → 403335		Enclosed instruction leaflet

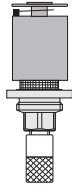
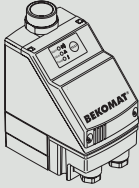
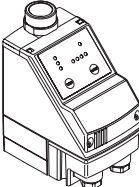
### 13.3 Accessories attachment components bottom

Designation	Figure	Separate documentation
Float drain (opened when pressureless) → 4025536  Float drain (closed when pressureless) → 4025537		Enclosed instruction leaflet
BEKOMAT® 20 → 4001841		Enclosed installation and operation manual
BEKOMAT® 20 FM → 4003051		Enclosed installation and operation manual
Compressed air heater S040 → 4012609  Compressed air heater S050 → 4012888		Enclosed installation and operation manual

## 14. Troubleshooting / FAQ

Error or fault pattern	Possible causes	Remedy
Poor compressed gas quality	Excessive load, load surges	<ul style="list-style-type: none"> <li>• Change operating method</li> <li>• Avoid pressure surges</li> <li>• Observe the prescribed operating parameters, particularly during start-up processes</li> </ul>
	Non-functioning condensate discharge	<ul style="list-style-type: none"> <li>• Guarantee regular condensate discharge</li> </ul>
	Incorrect dimensioning	<ul style="list-style-type: none"> <li>• Dimension the filter according to the given operating parameters and replace if necessary</li> </ul>
	Filter element installed incorrectly	<ul style="list-style-type: none"> <li>• Watch direction of flow / direction of installation of the filter element</li> </ul>
High differential pressure	O-ring has been damaged during installation	<ul style="list-style-type: none"> <li>• Procure new filter element and O-ring, proceed with care during installation</li> </ul>
	Incorrect dimensioning	<ul style="list-style-type: none"> <li>• Dimension the filter according to the given operating parameters and replace by larger one if necessary</li> </ul>
	Excessive contamination	<ul style="list-style-type: none"> <li>• Shorten the maintenance interval for filter element replacement</li> <li>• Filtration in stages may be necessary</li> </ul>
Condensate in downstream components	Filter elements destroyed	<ul style="list-style-type: none"> <li>• Change in operating method</li> <li>• Filtration in stages may be necessary</li> </ul>
	Condensate discharge defective or malfunctioning	<ul style="list-style-type: none"> <li>• Replace float drain or carry out maintenance on BEKOMAT®</li> </ul>
Leakage	Cooling downstream of filtration section	<ul style="list-style-type: none"> <li>• Drying upstream of filtration required</li> </ul>
	Ageing seals	<ul style="list-style-type: none"> <li>• Replace seals within the context of maintenance work</li> </ul>
	Mechanical damage	<ul style="list-style-type: none"> <li>• Send in the filter for repair or replace by a new one</li> </ul>

## 15. Product approvals and registration marks

Symbol/Pictogram	Description/Explanation
	CE marking on the filter Applicable for sizes M020, M022, M025, M027, M030 und M032





**BEKO TECHNOLOGIES GMBH**  
Im Taubental 7  
41468 Neuss

GERMANY

Tel: +49 2131 988-0  
www.beko-technologies.com



## Herstellererklärung

Wir erklären hiermit, dass die nachfolgend bezeichneten Produkte, in den von uns gelieferten Ausführungen gemäß Druckgeräte richtlinie 2014/68/EU Artikel 4 Absatz 3 in Übereinstimmung mit der geltenden guten Ingenieurpraxis ausgelegt und hergestellt werden.

Produktbezeichnung:	Behälter für Gewindefilter
Typbezeichnung:	CLEARPOINT
Baugröße:	S040, S045, S050, S055, S075, S100, M010, M012, M015, M018
Max. Betriebsdruck:	16 bar
Beschreibung der Druckgeräte:	Druckgeräte für Fluide der Gruppe 2

Druckgeräte nach Artikel 4 Absatz 3 der Druckgeräte richtlinie 2014/68/EU dürfen nicht die in Artikel 19 genannte CE-Kennzeichnung tragen.

Die Behälter wurden einer hydraulischen Druckprüfung mit 23 bar, und einer Dichtheitsprüfung mit dem Medium Druckluft, bei 7,0 bar unterzogen. Bei den durchgeführten Prüfungen zeigten sich keine Mängel.

Neuss, 30.07.2019

**BEKO TECHNOLOGIES GMBH**

i.V. Christian Riedel  
Leiter Qualitätsmanagement International

**BEKO TECHNOLOGIES GMBH**  
Im Taubental 7  
41468 Neuss

GERMANY

Phone: +49 2131 988-0  
ww.beko-technologies.com



## Manufacturer Declaration

We hereby declare that the products indicated hereafter, in the condition in which they have been placed into circulation, have been designed and manufactured according to sound engineering practice, in compliance with Article 4, Paragraph 3 of the European Pressure Equipment Directive 2014/68/EC.

Product designation:	Vessel for threaded filter
Model designation:	CLEARPOINT
Construction size:	S040, S045, S050, S055, S075, S100, M010, M012, M015, M018
Max. operating pressure:	16 bar
Description of the pressure equipment:	Pressure equipment for fluids of Group 2

Pressure equipment according to Article 4, Paragraph 3 of the European Pressure Equipment Directive 2014/68/EC must not bear the CE marking referred to in Article 19 of the above Directive.

The vessel was subjected to a hydraulic pressure test with 23 bar and a leakage test with a compressed air media at 7.0 bar. The vessel passed both tests successfully and no defects were detected.

Neuss, 30.07.2019

**BEKO TECHNOLOGIES GMBH**

i.V. Christian Riedel  
Head of International Quality Management

**BEKO TECHNOLOGIES GMBH**  
 Im Taubental 7  
 41468 Neuss

GERMANY

Tel: +49 2131 988-0  
 www.beko-technologies.com



## EU-Konformitätserklärung

Wir erklären hiermit, dass die nachfolgend bezeichneten Produkte den Anforderungen der einschlägigen Richtlinien und technischen Normen entsprechen. Diese Erklärung bezieht sich nur auf die Produkte in dem Zustand, in dem sie von uns in Verkehr gebracht wurden. Nicht vom Hersteller angebrachte Teile und/oder nachträglich vorgenommene Eingriffe bleiben unberücksichtigt.

Produktbezeichnung:	Behälter für Gewindefilter CLEARPOINT® ...
Modelle:	M020, M022, M023
Max. Betriebsdruck:	16 bar (g)
Produktbeschreibung und Funktion:	Behälter für CLEARPOINT Gewindefilter

### **Druckgeräte-Richtlinie 2014/68/EG**

Angewandtes Konformitätsbewertungsverfahren:	Modul A
Kategorie:	I
Beschreibung der Druckgeräte:	Druckgeräte für Fluide der Gruppe 2

Der Hersteller trägt die alleinige Verantwortung für die Ausstellung dieser Konformitätserklärung.

Unterzeichnet für und im Namen von:

Neuss, 22.07.2016

**BEKO TECHNOLOGIES GMBH**

i.V. Christian Riedel  
 Leiter Qualitätsmanagement International

**BEKO TECHNOLOGIES GMBH**  
 Im Taubental 7  
 41468 Neuss

GERMANY

Phone: +49 2131 988-0  
 www.beko-technologies.com



## EU Declaration of Conformity

We hereby declare that the products named below comply with the stipulations of the relevant directives and technical standards. This declaration only refers to products in the condition in which they have been placed into circulation. Parts which have not been installed by the manufacturer and/or modifications which have been implemented subsequently remain unconsidered.

Product designation:	Vessel for threaded filter CLEARPOINT® ...
Type:	M020, M022, M023
Maximum operating pressure:	16 bar (g)
Product description and function:	Vessel for CLEARPOINT threaded filter

### Pressure Equipment Directive 2014/68/EC

Applied conformity assessment procedure:	Module A
Category:	I
Description of the pressure equipment:	Pressure equipment for fluids of Group 2

The manufacturer shall have sole responsibility for issuing this declaration of conformity.

	Signed for and on behalf of:
Neuss, 22.07.2016	<b>BEKO TECHNOLOGIES GMBH</b>

i.V. Christian Riedel  
 Head of International Quality Management

**BEKO TECHNOLOGIES GMBH**  
Im Taubental 7  
41468 Neuss

GERMANY

Tel: +49 2131 988-0  
www.beko-technologies.com



## EU-Konformitätserklärung

Wir erklären hiermit, dass die nachfolgend bezeichneten Produkte den Anforderungen der einschlägigen Richtlinien und technischen Normen entsprechen. Diese Erklärung bezieht sich nur auf die Produkte in dem Zustand, in dem sie von uns in Verkehr gebracht wurden. Nicht vom Hersteller angebrachte Teile und/oder nachträglich vorgenommene Eingriffe bleiben unberücksichtigt.

Produktbezeichnung:	Behälter für Gewindefilter CLEARPOINT® ...
Modelle:	M025, M027, M030, M032
Max. Betriebsdruck:	16 bar (g)
Produktbeschreibung und Funktion:	Behälter für CLEARPOINT Gewindefilter

### Druckgeräte-Richtlinie 2014/68/EU

Angewandtes Konformitätsbewertungsverfahren:	Modul A2
Kategorie:	II
Beschreibung der Druckgeräte:	Druckgeräte für Fluide der Gruppe 2
Notifizierte Stelle:	TÜV NORD Systems GmbH & Co. KG Große Bahnstraße 31 22525 Hamburg
Zertifikatsnummer:	07/202/1410/Z/0237/17/D/0035

Die Produkte sind mit dem abgebildeten Zeichen gekennzeichnet:

**CE0045**

Der Hersteller trägt die alleinige Verantwortung für die Ausstellung dieser Konformitätserklärung.

Unterzeichnet für und im Namen von:

Neuss, 01.09.2017

**BEKO TECHNOLOGIES GMBH**

  
i.V. Christian Riedel  
Leiter Qualitätsmanagement International

**BEKO TECHNOLOGIES GMBH**  
Im Taubental 7  
41468 Neuss

GERMANY

Phone: +49 2131 988-0  
www.beko-technologies.com



## EU Declaration of Conformity

We hereby declare that the products named below comply with the stipulations of the relevant directives and technical standards. This declaration only refers to products in the condition in which they have been placed into circulation. Parts which have not been installed by the manufacturer and/or modifications which have been implemented subsequently remain unconsidered.

Product designation:	Vessel for threaded filter CLEARPOINT® ...
Type:	M025, M027, M030, M032
Maximum operating pressure:	16 bar (g)
Product description and function:	Vessel for CLEARPOINT threaded filter

### Pressure Equipment Directive 2014/68/EU

Applied conformity assessment procedure:	Module A2
Category:	II
Description of the pressure equipment:	Pressure equipment for fluids of Group 2
Notified body:	TÜV NORD Systems GmbH & Co. KG Große Bahnstraße 31 22525 Hamburg Germany
Certificate number:	07/202/1410/Z/0237/17/D/0035

The products bear the CE Mark:

**CE0045**

The manufacturer shall have sole responsibility for issuing this declaration of conformity.

Signed for and on behalf of:

Neuss, **01/09/2017** BEKO TECHNOLOGIES GMBH

i.V. Christian Riedel  
Head of International Quality Management

**BEKO TECHNOLOGIES GmbH**

Im Taubental 7  
D - 41468 Neuss  
Tel. +49 2131 988 0  
Fax +49 2131 988 900  
info@beko-technologies.com

**DE****BEKO TECHNOLOGIES LTD.**

Unit 11-12 Moons Park  
Burnt Meadow Road  
North Moons Moat  
Redditch, Worcs, B98 9PA  
Tel. +44 1527 575 778  
info@beko-technologies.co.uk

**GB****BEKO TECHNOLOGIES S.à.r.l.**

Zone Industrielle  
1 Rue des Frères Rémy  
F - 57200 Sarreguemines  
Tél. +33 387 283 800  
info@beko-technologies.fr

**FR****BEKO TECHNOLOGIES B.V.**

Veenen 12  
NL - 4703 RB Roosendaal  
Tel. +31 165 320 300  
benelux@beko-technologies.com

**NL****BEKO TECHNOLOGIES  
(Shanghai) Co. Ltd.**

Rm. 606 Tomson Commercial Building  
710 Dongfang Rd.  
Pudong Shanghai China  
P.C. 200122  
Tel. +86 21 508 158 85  
info.cn@beko-technologies.cn

**CN****BEKO TECHNOLOGIES s.r.o.**

Na Pankraci 58  
CZ - 140 00 Praha 4  
Tel. +420 24 14 14 717 /  
+420 24 14 09 333  
info@beko-technologies.cz

**CZ****BEKO Tecnológica España S.L.**

Torruella i Urpina 37-42, nave 6  
E - 08758 Cervelló  
Tel. +34 93 632 76 68  
Mobil +34 610 780 639  
info.es@beko-technologies.es

**ES****BEKO TECHNOLOGIES LIMITED**

Unit 1010 Miramar Tower  
132 Nathan Rd.  
Tsim Sha Tsui Kowloon Hong Kong  
Tel. +852 5578 6681 (Hong Kong)  
+86 147 1537 0081 (China)  
tim.chan@beko-technologies.com

**HK****BEKO TECHNOLOGIES INDIA Pvt. Ltd.**

Plot No.43/1 CIEEP Gandhi Nagar  
Balanagar Hyderabad  
IN - 500 037  
Tel. +91 40 23080275 /  
+91 40 23081107  
Madhusudan.Masur@bekoindia.com

**IN****BEKO TECHNOLOGIES S.r.l**

Via Peano 86/88  
I - 10040 Leini (TO)  
Tel. +39 011 4500 576  
Fax +39 0114 500 578  
info.it@beko-technologies.com

**IT****BEKO TECHNOLOGIES K.K**

KEIHIN THINK Building 8 Floor  
1-1 Minamiwatarida-machi  
Kawasaki-ku, Kawasaki-shi  
JP - 210-0855  
Tel. +81 44 328 76 01  
info@beko-technologies.jp

**JP****BEKO TECHNOLOGIES Sp. z o.o.**

ul. Pańska 73  
PL - 00-834 Warszawa  
Tel. +48 22 314 75 40  
info.pl@beko-technologies.pl

**PL****BEKO TECHNOLOGIES S.E.Asia  
(Thailand) Ltd.**

75/323 Soi Romklao, Romklao Road  
Sansab Minburi  
Bangkok 10510  
Tel. +66 2-918-2477  
info.th@beko-technologies.com

**TH****BEKO TECHNOLOGIES Co.,Ltd**

16F.-5 No.79 Sec.1  
Xintai 5th Rd., Xizhi City  
New Taipei City 221  
Taiwan (R.O.C.)  
Tel. +886 2 8698 3998  
info.tw@beko-technologies.tw

**TW****BEKO TECHNOLOGIES CORP.**

900 Great Southwest Pkwy SW  
US - Atlanta, GA 30336  
Tel. +1 404 924-6900  
Fax +1 (404) 629-6666  
beko@bekousa.com

**US**