



Process technology | CLEARPOINT® V

Achieving minimum residual oil concentrations at affordable prices: CLEARPOINT® V activated carbon adsorber

The CLEARPOINT® V activated carbon adsorber is the ideal solution for top quality compressed air with a residual oil content of maximum 0.003 mg/m³.

The CLEARPOINT® V activated carbon adsorber is not only extremely efficient and reliable, but also very cost-effective. It has become an indispensable component in compressed air processing plants. Advanced overall design for outstanding performance.

The perfect match

CLEARPOINT® V activated carbon adsorbers are available as combined units including a METPOINT® OCV compact residual oil vapour measuring system. The METPOINT® OCV compact allows for the continuous online monitoring and documentation of the residual oil vapour concentration measured directly at the compressed air outlet of the activated carbon adsorber. The METPOINT® OCV compact boosts the process safety of your system.

- › **Efficient oil vapour adsorption with special activated carbon**
- › **Reduced operating costs thanks to low differential pressure and long service life**
- › **Complete solution with oil-free dust filter**
- › **Available with optional oil test indicator or METPOINT OCV compact residual oil content monitoring unit for extra safety in production processes**



Residual oil aerosol and vapour content at outlet:

better than DIN ISO 8573-1 class 1
(max. 0.003 mg/m³ at 20 °C and 1 bar [a])
for solids up to 1 µm;
for more stringent requirements, install
0.01 µm dust filter

Inlet air: Pressure dew point < 7 °C
(corresponding to rel. humidity < 35% at
25 °C or 20% at 35 °C)
Residual oil aerosol concentration max. 0.01 mg/m³
at 20 °C and 1 bar [a]

Note: At high oil aerosol concentrations
(> 2 mg/m³) at the inlet, install multi-stage
prefiltration

Adsorber operating temperature:
max. 50 °C, recommended 35 °C

Max. operating pressure: 16 bar [gauge],
from L 295 V: 11 bar [gauge]

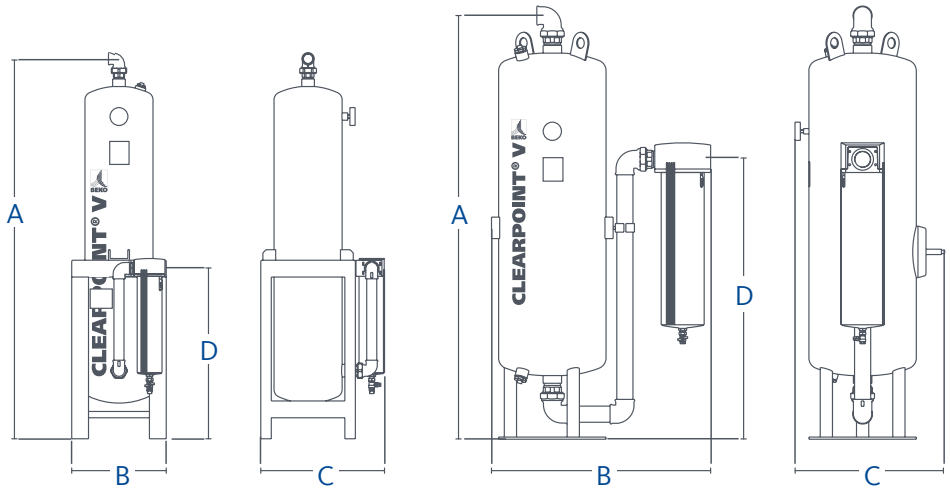

CLEARPOINT® V	L205 VWM	L210 VWM	L215 VWM	L220 VWM	L225 VWM	L230 VWM	L240 VWM	L250 VWM	L260 VWM	L275 VWM	L295 VWM
Service life* at 35 °C [h]	10,000	10,000	10,000	10,000	10,000	10,000	10,000	10,000	10,000	10,000	10,000
Connection	G1	G1	G1	G1 1/2	G1 1/2	G1 1/2	G2	G2	G2 1/2	G2 1/2	G2 1/2
Volume flow rate 7 bar [g] (m ³ /h)	135	155	200	280	380	500	630	800	1000	1250	1550
Dimensions											
A (in mm)	1580	1490	1490	1850	1850	1810	1980	1940	1980	1980	2080
B (in mm)	340	340	340	450	450	450	735	935	1020	1020	1085
C (in mm)	440	440	440	590	590	590	565	595	700	700	730
D (in mm)	680	680	680	810	810	810	1430	1430	1305	1305	1310
Weight (kg)	65	95	95	145	145	172	210	240	300	300	380
Category according to PED 2014/68/EU, Fluid group 2	II	II	II	III	III	III	III	III	IV	IV	IV

The above performance data apply to the following operating conditions:
* 7 bar [gauge], 35 °C, rel. humidity 30 %

Deviating operating pressures require different adsorber sizes.
Deviating inlet temperatures affect the service life of the activated carbon.
When choosing an activated carbon adsorber for your specific application, contact our specialists.

Correction factors for size and service life

Operating pressure bar [gauge]	4	5	6	7	8	9	10	11	12	13	14	15	16
Fp	0.62	0.75	0.88	1	1.08	1.15	1.21	1.26	1.3	1.37	1.43	1.48	1.53
Inlet temperature [°C]	35° C			40° C			45° C			50° C			
Ft	1			1.33			1.54			1.82			

Residual oil aerosol and vapour content at outlet:

better than DIN ISO 8573-1 class 1
(max. 0.003 mg/m³ at 20 °C and 1 bar [a])
for solids up to 1 µm;
for more stringent requirements, install
0.01 µm dust filter

Inlet air: Pressure dew point < 7 °C
(corresponding to rel. humidity < 35% at
25 °C or 20% at 35 °C)

Residual oil aerosol concentration max. 0.01 mg/m³
at 20 °C and 1 bar [a]

Note: At high oil aerosol concentrations
(> 2 mg/m³) at the inlet, install multi-stage
prefiltration

Adsorber operating temperature:
max. 50 °C, recommended 35 °C

Max. operating pressure: 16 bar [gauge],
from L 295 V: 11 bar [gauge]

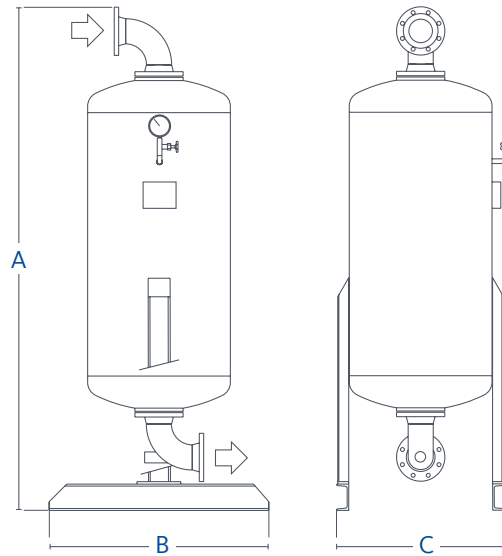

Flange connection

CLEARPOINT® V	L1250 V	L1550 V	L1700 V	L2000 V	L2300 V	L2600 V	L2900 V
Service life* [h] at 35 °C	10,000	10,000	10,000	10,000	10,000	10,000	10,000
Connection	65	65	80	80	100	100	100
Volume flow rate 7 bar [g] (m ³ /h)	1250	1550	1700	2000	2300	2600	2900
Dimensions							
A (in mm)	2300	2270	2335	2360	2480	2500	2520
B (in mm)	700	750	750	850	850	1000	1000
C (in mm)	680	755	805	855	905	955	1005
Activated carbon (kg)	130	165	180	210	245	280	310
Weight (kg)	355	420	500	600	670	750	820
Category according to PED 2014/68/EU Fluid group 2	IV	IV	IV	IV	IV	IV	IV

CLEARPOINT® V	L3400 V	L4200 V	L5000 V	L6000 V	L7000 V	L8200 V
Service life* at 35 °C	10,000	10,000	10,000	10,000	10,000	10,000
Connection	100	150	150	150	150	150
Volume flow rate 7 bar [g] (m ³ /h)	3400	4200	5000	6000	7000	8200
Dimensions						
A (mm)	2540	2810	2870	2930	2970	3010
B (mm)	1000	1100	1250	1250	1450	1450
C (mm)	1055	1030	1130	1225	1345	1445
Activated carbon (kg)	360	440	530	635	740	870
Weight (kg)	920	1120	1370	1630	1930	2220
Category according to PED 2014/68/EU Fluid group 2	IV	IV	IV	IV	IV	IV

The above performance data
apply to the following operating conditions:
* 7 bar [gauge], 35 °C, rel. humidity 30 %

Deviating operating pressures require different adsorber sizes.
Deviating inlet temperatures affect the service life of the activated carbon.
When choosing an activated carbon adsorber for your specific application, contact our specialists.

Do **you** have questions about the best way to achieve high quality compressed air?

Then we have the answers! We offer efficient solutions for any type of processing chain. Please contact us with all your queries. We would be delighted to tell you more about our condensate

treatment, filtration, drying, measuring technology and process technology, as well as our extensive services.

Visit us on



BEKO TECHNOLOGIES GMBH
Im Taubental 7 | D-41468 Neuss

Tel. +49 2131 988 - 1000
info@beko-technologies.com
www.beko-technologies.com

